

# XIS-7858™

## PRODUCT HIGHLIGHTS

Artificial Intelligence (AI)

Enhanced Imaging™

Minimal System Profile

Windows® Operating System  
with Intel® Core™ Processor

Real-Time Diagnostics



## PRODUCT DESCRIPTION

The XIS-7858™ is a compact X-Ray Inspection System (XIS) featuring a small footprint and wide tunnel dimensions, ideal for screening large baggage and parcels at sites with limited space. The XIS-7858™ is equipped with the full range of Astrophysics imaging tools, enabling in-depth analysis of complex, multi-layered bags. The #1 global manufacturer of critical infrastructure products, Astrophysics is the clear choice.

## ABOUT ASTROPHYSICS

Since 2002, Astrophysics has led the industry in research and development, creating integrated solutions to advance the critical security missions of our customers and partners. Headquartered outside of Los Angeles, CA in the USA, Astrophysics has over 40,000 systems deployed in more than 150 countries, safeguarding critical infrastructure, aviation, and ports and border sites worldwide.

# XIS-7858™

## GENERAL SPECIFICATIONS

Tunnel Size:	77.7 cm x 57.9 cm 30.6" x 22.8"
Dimensions: <sup>1</sup> (LxWxH)	229.3 cm x 100.6 cm x 140.0 cm 90.3" x 39.6" x 55.1"
Shipping Dimensions: <sup>1</sup> (LxWxH)	243.8 cm x 113.0 cm x 160.0 cm 96.0" x 44.5" x 63.0"
Net Weight: <sup>1</sup>	640 kg (1412 lbs)
Shipping Weight: <sup>1</sup>	737 kg (1625 lbs)
Conveyor Speed:	23 cm/s (45 ft/min) Forward or Reverse
Conveyor Height:	69.1 cm (27.2") from Floor
Conveyor Capacity:	165 kg (364 lbs) Evenly Distributed Load

## X-RAY GENERATOR & IMAGE PERFORMANCE

Voltage:	180kV, Operating at 165kV
Tube Current:	1.2 mA
Wire Resolution: <sup>2</sup>	40 AWG Typical, 38 AWG Standard
Steel Penetration: <sup>2</sup>	39 mm Typical, 37 mm Standard
Cooling:	Sealed Di-Electric Oil Bath with Forced Air
Duty Cycle:	100%, No Warm-Up Procedure Required
Beam Direction:	Diagonally Upward

## COMPUTER & VIDEO

Platform:	Windows® 10 OS
Memory:	8 GB RAM
Storage Capacity:	256 GB SSD
Display Type:	Dual 21.5" Flat Panel Monitors
Display Resolution:	1920 x 1080

## ENVIRONMENTAL

Operating Temperature:	0°C to 40°C / 32°F to 104°F
Storage Temperature:	-20°C to 60°C / -4°F to 140°F
Humidity:	Up To 95% Non-Condensing

## ELECTRICAL

System Power:	110 VAC +/- 10% 50/60Hz, 15 Amp Max 220 VAC +/- 10% 50/60Hz, 10 Amp Max
Power Conditioner:	Automatic Voltage Regulator (AVR), 600VA

## HEALTH & SAFETY

Compliant with USFDA Center for Devices and Radiation Health Standards for Cabinet X-Ray Systems (21-CFR 1020.40)  
Typical radiation leakage is less than 0.1 mR/hr  
(Leakage less than 0.5 mR/hr permitted by U.S. Federal Standards)

## FEATURES

### STANDARD

3 & 6 Color Imaging  
Black & White Imaging  
Enhanced Imaging™  
High Penetration Function  
Organic/Inorganic Imaging  
Pseudo Color  
Reverse Monochrome

Atomic Z-Number Measurement  
Geometric Image Distortion Correction  
Material Discrimination  
Real-Time Image Manipulation

Auto Image Archiving  
Image Review  
Save Image (RGB)

Baggage Counter

Image Annotation  
JPEG Conversion  
Print Image Capable

Multi-Tier Accessibility  
Network Ready  
Real-Time Self Diagnostics

9 Quadrant Zoom  
Continuous Scanning  
Continuous Zoom Up to 64x  
Vertical Zoom Panning

### OPTIONAL

Density Alert  
Local Language  
Safe Passage® Computer Based Training  
Screener Assist Software  
Test Case  
Threat Image Projection (TIP) Software

Dual 24" Flat Panel Monitors  
Custom Paint  
Entry/Exit Roller Tables  
Environmental Kit  
Footmat Operator Interlock  
Internal/External UPS  
Long Conveyor  
Roller Bed  
Radiation Meter  
Remote Workstation Configuration

External USB Ports  
Conveyor Capacity Load Increase  
Variable Conveyor Speed  
8-Color Imaging

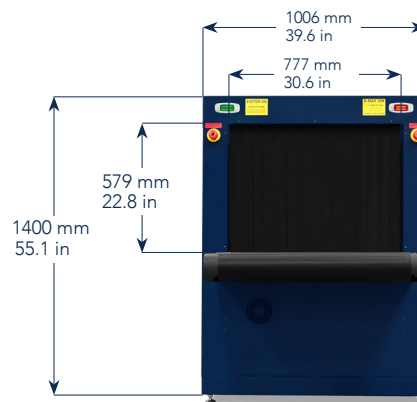

## ISO 9001 & ISO 14001 CERTIFIED



<sup>1</sup>Weight and dimensions of the system may vary depending on customization.

<sup>2</sup>As tested on Astrophysics Inc. Test Piece.

<sup>3</sup>Optional Features may affect lead time, price, and weight of product. Please contact your Astrophysics Sales Representative for more information.

Due to continued product development, Astrophysics Inc. reserves the right to amend all technical specifications without prior notice.  
Contact [sales@astrophysicsinc.com](mailto:sales@astrophysicsinc.com) for the most updated brochures.

