



# WPEA-250GN

## Feature

- Chipset: Atheros AR9287
- Interface: Mini PCI Express
- Wireless connection up to 300Mbps
- RF 2T2R
- Output Power up to 16dBm
- Enhanced wireless security: WEP, WPA, WPA2
- Support Windows XP/ Vista, Win 7, Linux, Android by request



## 802.11b/g/n Half Mini Card

*Performance with Atheros AR9287 Solution, 2T2R, up to 300Mbps Data Rate*

### Superior Performance for Multimedia Networking

SparkLAN WPEA-250GN is an 802.11b/g/n Single-Band Half Mini Card based on Atheros AR9287 chipset. It supports 2T2R function, which provides maximum data rate up to 300Mbps and improves the overall Wi-Fi coverage area.

### Secure Wireless Connection

This Half Mini Card, WPEA-250GN, incorporated advanced security encryption, such as WPA, and WPA2, to help prevent users' devices from malicious attacks.

## Application

- Networking Equipment
- Industrial Computers
- Automation
- Medical Device
- POS (Point-of-Sale) System
- Self-Service KIOSK
- Gaming Machine



03-9243352 :70  
 03-9243358 :0p9  
 sales@hypertech.co.il  
 www.hypertech.co.il

### Mechanical Dimension (mm)

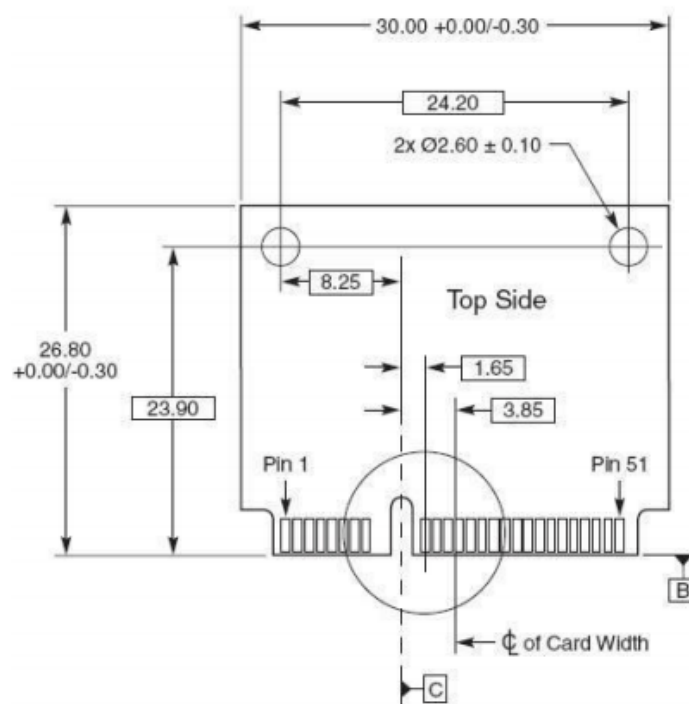



# WPEA-250GN

## Related Product

- WPEA-152GN(BT)  
 802.11b/g/n WiFi + Bluetooth  
 Half Mini Card



- WPEA-121N  
 802.11a/b/g/n Half Mini Card

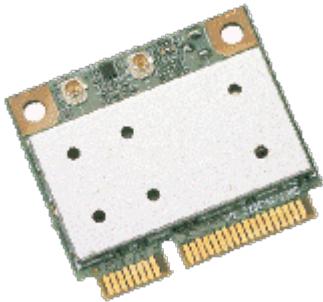

## Ordering Info

- WPEA-250GN  
 802.11b/g/n Half Mini Card

## Specifications

### Standard

802.11b/g/n

### Chipset

Mac/BB/RF                      Atheros AR9287

### Host Interface

Mini PCI Express

### Radio

Antenna                      2 x U.FL connectors, 2T2R

Operating Frequency      b/g/n ISM Band: 2.400~2.4835GHz

Modulation                      802.11b: DSSS (DBPSK, DQPSK, CCK)  
 802.11g: OFDM (BPSK, QPSK, 16-QAM, 64-QAM)  
 802.11n: OFDM (BPSK, QPSK, 16-QAM, 64-QAM)

Output Power (1T)              802.11b: 16dBm ± 2dBm@11Mbps  
 802.11g: 11dBm ± 2dBm@54Mbps  
 802.11gn HT20: 9dBm ± 2dBm@MCS7  
 802.11gn HT40: 8dBm ± 2dBm@MCS7

Receive Sensitivity (2R)      802.11b: -83dBm ± 2dBm@11Mbps  
 802.11g: -70dBm ± 2dBm@54Mbps  
 802.11gn HT20: -67dBm ± 2dBm@MCS7  
 802.11gn HT40: -65dBm ± 2dBm@MCS7

### Power consumption

Continue TX                      570mA

Continue RX                      530mA

### Operating Voltage

DC 3.3V ± 10%

### Environmental

Temperature Range          0 ~ 75°C (Operating)    -40~80°C (Storing)

Humidity (Non-Condensing)    5 ~ 90% (Operating)    5% ~ 95% (Storage)

### Physical Specification

Dimensions                      30mm x 26.8mm x 3.45mm

Weight                              ≤9g

### Software

Driver                              Windows XP/ Vista, Win 7, Linux, Android by request

Security                              WEP, WPA, WPA2



רח' אודם 14, ת.ד. 7042 פ"ת ■ טל: 03-9243352 ■ פקס: 03-9243358  
[www.hypertech.co.il](http://www.hypertech.co.il) ■ [sales@hypertech.co.il](mailto:sales@hypertech.co.il)