

CSR BLUETOOTH MODULES

SBC05-AT



Specification

Version 1.11

14-July-11

Features:

- CSR BlueCore05 Chip
- Bluetooth v2.1 + EDR
- Class2
- S/W Supported :
AT command
- Dimension: 12.5X12.5X2.2mm
- Slave only

Product No.: SBC05-AT

Product Description:

Bluetooth v2.1 Class 2 BT Stereo Module

Issue Date: 2011/07/14

Release Version: 1.11

1. Hardware & Technical Information

1.1 Pin Definition

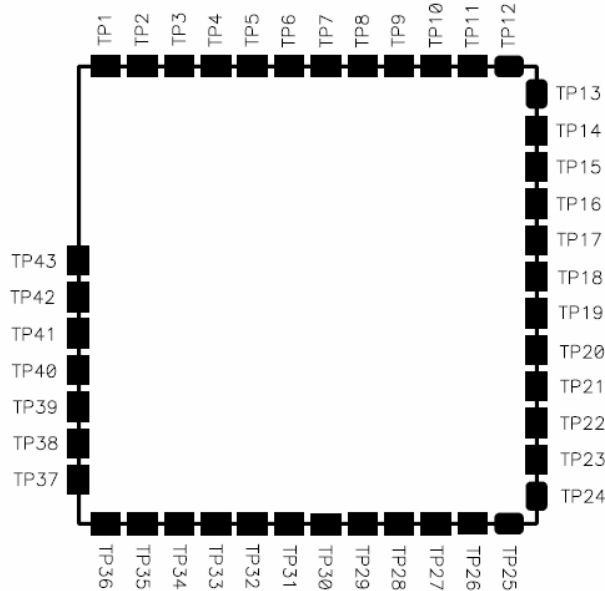

PIN	Name	Type	Note
1	VCC3.3V	(I)	
2	AIO0	(I)	
3	PIO6	(I/O)	
4	PIO5	(I/O)	
5	PIO4	(I/O)	
6	PIO3	(I/O)	
7	PIO2	(I/O)	
8	PIO1	(I/O)	
9	PIO0	(I/O)	
10	GND		
11	RF_OUT		
12	GND		
13	MIC_BIAS		
14	MIC_A_N		
15	MIC_A_P		
16	MIC_B_N		
17	MIC_B_P		
18	VDD_AUDIO_1.5V		
19	PCM_CLK		
20	PCM_SYNC		
21	PCM_IN		
22	PCM_OUT		
23	BAT_CHARGE_IN		
24	VDD_BAT		

25	RESET		
26	LED0	(Out)	
27	LED1	(Out)	
28	SPI_MISO		
29	SPI_CS		
30	SPI_CLK		
31	SPI_MOSI		
32	UART_RX		
33	UART_TX		
34	UART_CTS		
35	UART_RTS		
36	USB_D+		
37	USB_D-		
38	SPKR_B_N		
39	SPKR_B_P		
40	SPKR_A_N		
41	SPKR_A_P		
42	GND		
43	VEGENABLE_H	(I)	Pull Hi

VCC3.3

Supply voltage connection for the digital I/Os of the module. Supply voltage at this pin with 3.3 V.

GND

Connect GND pins to the ground plane of the PCB.

VDD_BAT

Input for an internal 1.8 V switched mode regulator combined with output of the internal battery charger. When not powered from a battery, VCC3.3 and VDD_BAT can be combined to a single 3.3 V supply voltage.

VEGENABLE_H

Enable pin for the internal 1.8 V regulator. Connect this pin to 3.3V

BAT_CHARGE_IN

Charger input voltage. The charger will start operating when voltage to this pin is applied. When the charger is not used, this pin should be left floating.

RESET

The RESET pin is an active low reset.

PIO0 – PIO6

Programmable digital I/O lines. All PIO lines can be configured through software to have either weak or strong pull-ups or pull-downs. Configuration for each PIO line depends on the application. Please check Default configuration in Standard Setup Information.

AIO0

AIO can be used to monitor analogue voltages such as a temperature sensor for the battery charger. AIO can also be configured to be used as digital I/Os. The default setting is None function.

UART_RTS

A CMOS output with a weak internal pull-up. This pin can be used to implement RS232 hardware flow control where RTS (request to send) is an active low indicator. The UART interface requires an external RS232 transceiver chip.

UART_CTS

A CMOS input with a weak internal pull-down. This pin can be used to implement RS232 hardware flow control where CTS (clear to send) is an active low indicator. The UART interface requires an external RS232 transceiver chip.

UART_RX

A CMOS input with a weak internal pull-down. RXD is used to implement UART data transfer from another device to SBC05. The UART interface requires an external RS232 transceiver chip.

UART_TX

A CMOS output with a weak internal pull-up. TXD is used to implement UART data transfer from SBC05 to another device. The UART interface requires external RS232 transceiver chip.

PCM_OUT

A CMOS output with a weak internal pull-down. Used in the PCM (pulse code modulation) interface to transmit digitized audio. The PCM interface is shared with the I²S interface.

PCM_IN

A CMOS input with a weak internal pull-down. Used in the PCM interface to receive digitized audio. The PCM interface is shared with the I²S interface.

PCM_CLK

A bi-directional synchronous data clock signal pin with a weak internal pull-down. PCMC is used in the PCM interface to transmit or receive the CLK signal. SBC05 configured as a slave, the PCMC is an input and receives the clock signal from another device. The PCM interface is shared with the I²S interface.

PCM_SYNC

A bi-directional synchronous data strobe with a weak internal pull-down. SBC05 configured as a slave, the PCMS is an input and receives the SYNC signal from another device. The PCM interface is shared with the I²S interface.

USB_D+

A bi-directional USB data line with a selectable internal 1.5 k Ω pull-up implemented as a current source. An external series resistor is required to match the connection to the characteristic impedance of the USB cable.

USB_D-

bi-directional USB data line. An external series resistor is required to match the connection to the characteristic impedance of the USB cable.

SPI_CSB

A CMOS input with a weak internal pull-down.

SPI_CLK

A CMOS input for the SPI clock signal with a weak internal pull-down.

SPI_MISO

An SPI data output with a weak internal pull-down.

SPI_MOSI

An SPI data input with a weak internal pull-down.

RF_OUT

This pin connect to chip antenna or printing antenna.

SPKR_B_P and SPKR_B_N

Right channel audio output. The audio output lines should be routed differentially to either the speakers or to the output amplifier, depending on whether or not a single-ended signal is required. Use low impedance ground plane dedicated for the audio signals.

SPKR_A_P and SPKR_A_N

Left channel audio output. The same guidelines apply to this section as discussed previously.

MIC_BIAS

Bias voltage output for a microphone. Use the same layout guidelines as discussed previously with other audio signals.

MIC_B_P and MIC_B_N

Right channel audio inputs. This dual audio input can be configured to be either single ended or fully differential and programmed for either microphone or line input. Route differential pairs close to each other and use a solid dedicated audio ground plane for the audio signals.

MIC_A_P and MIC_A_N

Left channel audio input. The same guidelines apply to this section as discussed previously.

1.2 Mechanical Specification

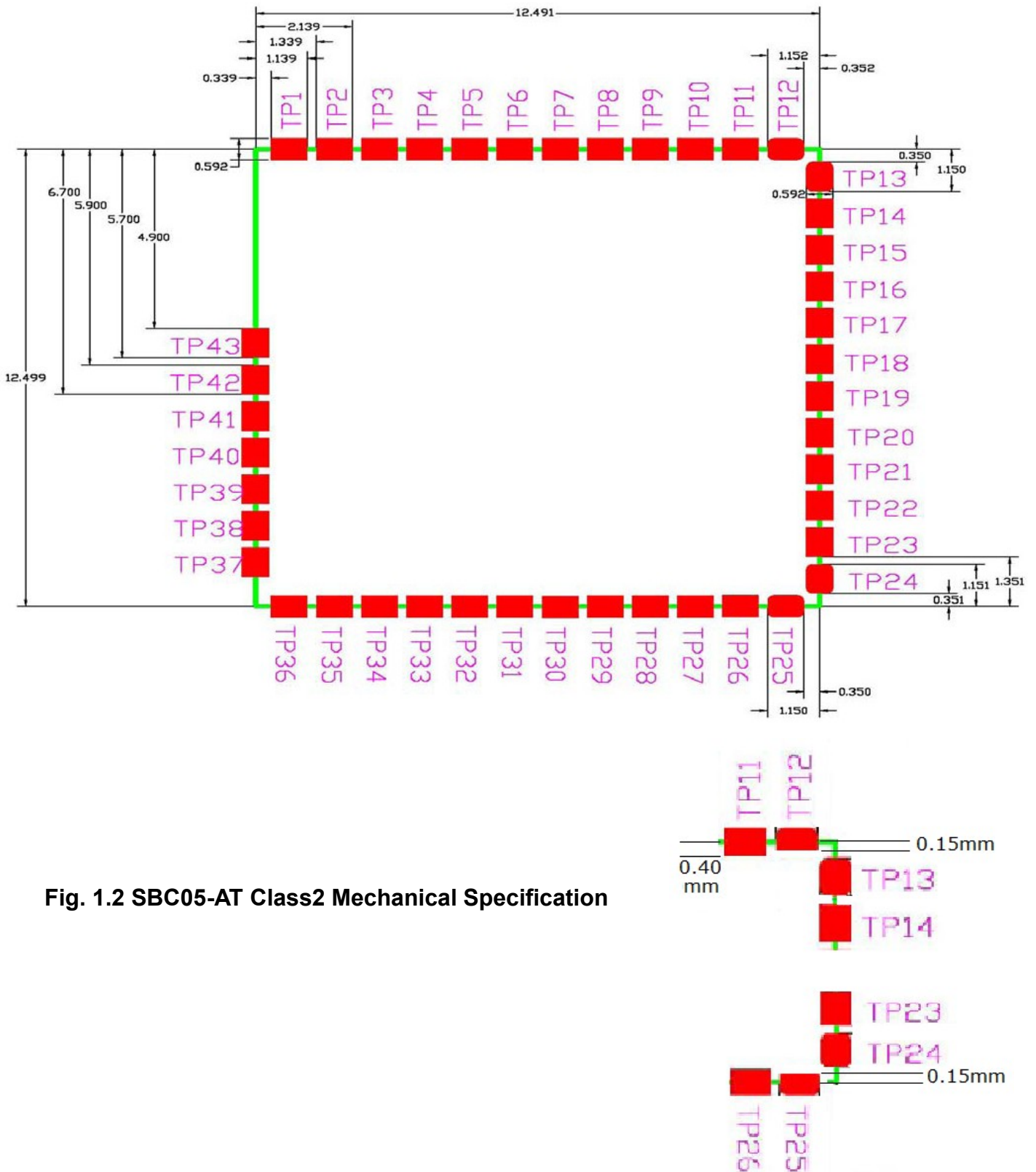
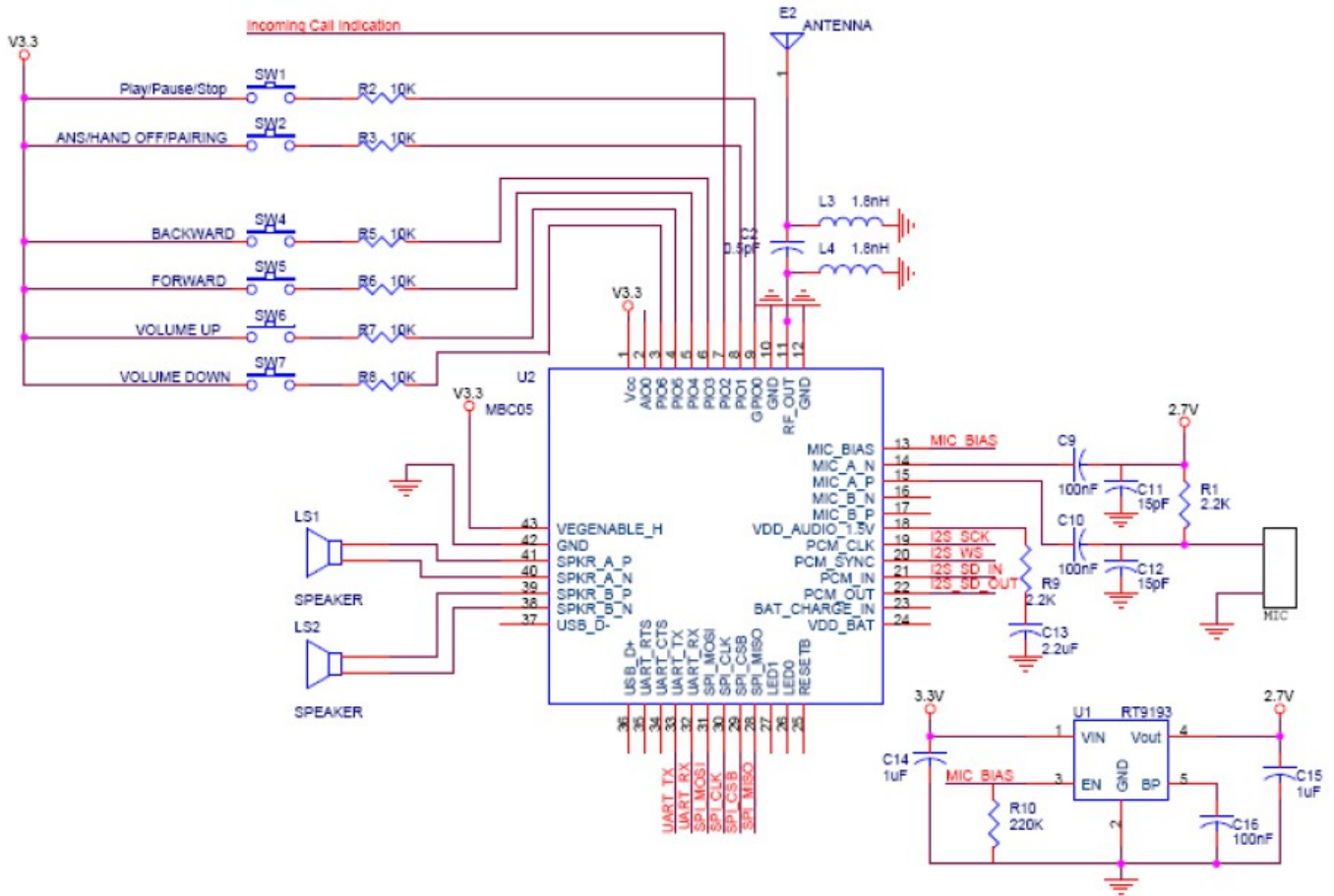

Fig. 1.2 SBC05-AT Class2 Mechanical Specification

Reference Schematics



1.3 Block Diagram

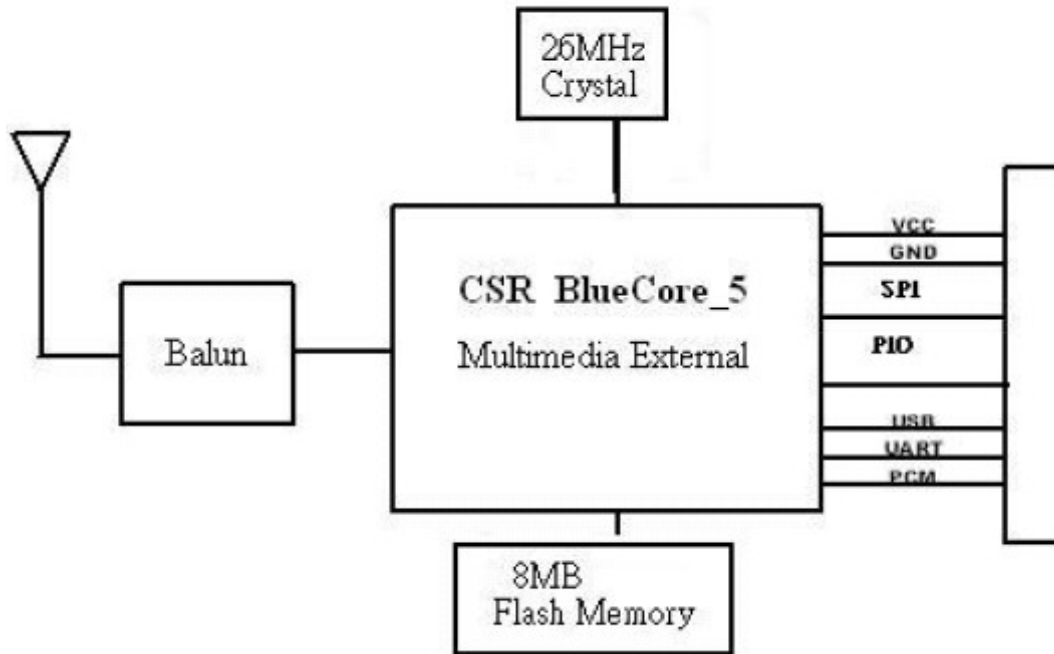

Fig 1.3 SBC05-AT Class2 Module Block Diagram

1.4 Electrical Characteristics

■ Voltage Input

	MIN	Typ.	MAX	Unit
Supply Voltage	3.0	3.3	3.6	V

■ Power Consumption

Mode	Avg.
Standby	1mA
Transmit	30mA
Receive	28mA
Pairing	26mA

■ Operating Conditions

Voltage Range	3.3V±0.3V
Operating Temperature Range	-20°C ~ 60°C
Storage Temperature Range	-20°C ~ 80°C
Relative Humidity (Operating)	≤90%
Relative Humidity (Storage)	≤90%

1.5 Radio Characteristics

	Frequency (GHz)	MIN	TYP	MAX	BT Spec	Unit
Sensitivity at 0.1%BER	2.402	≤-84	-80	-	≤ -70	dBm
	2.441	≤-84	-80	-		dBm
	2.480	≤-84	-80	-		dBm
RF Transmit Power	2.402	-2	0	4	≤ 4	dBm
	2.441	-2	0	4		dBm
	2.480	-2	0	4		dBm
Initial Carrier Frequency Tolerance	2.402	-	5	75	75	kHz
	2.441	-	5	75		kHz
	2.480	-	5	75		kHz
20dB bandwidth for modulated carrier		-	900	1000	≤1000	kHz
Drift (Five slots packet)		-	15	-	40	kHz
Drift Rate		-	13	-	20	kHz
$\Delta f1_{avg}$ "Maximum Modulation"	2.402	140	165	175	140 < $\Delta f1_{avg}$	kHz
	2.441	140	165	175		kHz
	2.480	140	165	175		kHz
$\Delta f2_{max}$ "Minimum Modulation"	2.402	115	190	-	115	kHz
	2.441	115	190	-		kHz
	2.480	115	190	-		kHz

2. Software specification

2.1 Profile

Stack / Profile	SBC05-AT (Class2 BT2.1 slave module)
A2DP	V
HSP	V
HFP	V
AVRCP	V

2.2 Software function

2.2.1 SBC05-AT

- a. SBC05-AT module will act only when you send AT command. You can find the detailed command list in "A2DP_AT_Commands.pdf" document.

3. Default setting Information

	Parameter	Value
1	Baud Rate	9600
2	Pin Code Prompt	
3	Local Name	
4	Master/Slave	

4. Pre-Test Report

The SBC05 module can pass the BQB certification after pre-test this module. We can provide the pre-test report under request.