



HUAWEI MU709 Series HSPA+ Mini PCIe Module

Hardware Guide

Issue 04

Date 2015-06-25



רח' אודם 14, ת.ד. 7042 פ"ת ▪ 03-9243352 :טל ▪ 03-9243358 :פקס
www.hypertech.co.il ▪ sales@hypertech.co.il

Copyright © Huawei Technologies Co., Ltd. 2015. All rights reserved.

No part of this manual may be reproduced or transmitted in any form or by any means without prior written consent of Huawei Technologies Co., Ltd. and its affiliates ("Huawei").

The product described in this manual may include copyrighted software of Huawei and possible licensors. Customers shall not in any manner reproduce, distribute, modify, decompile, disassemble, decrypt, extract, reverse engineer, lease, assign, or sublicense the said software, unless such restrictions are prohibited by applicable laws or such actions are approved by respective copyright holders.

Trademarks and Permissions



HUAWEI,

HUAWEI, and



are trademarks or registered trademarks of Huawei Technologies Co., Ltd.

Other trademarks, product, service and company names mentioned may be the property of their respective owners.

Notice

Some features of the product and its accessories described herein rely on the software installed, capacities and settings of local network, and therefore may not be activated or may be limited by local network operators or network service providers.

Thus, the descriptions herein may not exactly match the product or its accessories which you purchase.

Huawei reserves the right to change or modify any information or specifications contained in this manual without prior notice and without any liability.

DISCLAIMER

ALL CONTENTS OF THIS MANUAL ARE PROVIDED "AS IS". EXCEPT AS REQUIRED BY APPLICABLE LAWS, NO WARRANTIES OF ANY KIND, EITHER EXPRESS OR IMPLIED, INCLUDING BUT NOT LIMITED TO, THE IMPLIED WARRANTIES OF MERCHANTABILITY AND FITNESS FOR A PARTICULAR PURPOSE, ARE MADE IN RELATION TO THE ACCURACY, RELIABILITY OR CONTENTS OF THIS MANUAL.

TO THE MAXIMUM EXTENT PERMITTED BY APPLICABLE LAW, IN NO EVENT SHALL HUAWEI BE LIABLE FOR ANY SPECIAL, INCIDENTAL, INDIRECT, OR CONSEQUENTIAL DAMAGES, OR LOSS OF PROFITS, BUSINESS, REVENUE, DATA, GOODWILL SAVINGS OR ANTICIPATED SAVINGS REGARDLESS OF WHETHER SUCH LOSSES ARE FORSEEABLE OR NOT.

THE MAXIMUM LIABILITY (THIS LIMITATION SHALL NOT APPLY TO LIABILITY FOR PERSONAL INJURY TO THE EXTENT APPLICABLE LAW PROHIBITS SUCH A LIMITATION) OF HUAWEI ARISING FROM THE USE OF THE PRODUCT DESCRIBED IN THIS MANUAL SHALL BE LIMITED TO THE AMOUNT PAID BY CUSTOMERS FOR THE PURCHASE OF THIS PRODUCT.

Import and Export Regulations

Customers shall comply with all applicable export or import laws and regulations and be responsible to obtain all necessary governmental permits and licenses in order to export, re-export or import the product mentioned in this manual including the software and technical data therein.

Privacy Policy

To better understand how we protect your personal information, please see the privacy policy at <http://consumer.huawei.com/privacy-policy>



03-9243358 :0קפ ▪ 03-9243352 :70 ▪ ת"פ 7042 .ד.ת.14 ,אודם

www.hypertech.co.il ▪ sales@hypertech.co.il



About This Document

Revision History

Document Version	Date	Chapter	Descriptions
01	2014-09-15		Creation
02	2014-09-18	3.3.2	Updated section 3.3.2: Reset the Module
03	2015-02-16	All	Added the description of MU709s-6 module
04	2015-06-25	2.2	Updated Table 2-1: Features
		5.3	Updated Table 5-2: Operating and storage temperatures
		7.2	Updated Table 7-1: Product Certifications

Scope

MU709s-2

MU709s-6

Contents

1 Introduction.....	7
2 Overall Description	8
2.1 About This Chapter.....	8
2.2 Function Overview.....	8
2.3 Circuit Block Diagram.....	9
3 Description of the Application Interfaces.....	11
3.1 About This Chapter.....	11
3.2 Mini PCIe Interface.....	11
3.3 Power Interface	16
3.3.1 Sources and Grounds.....	16
3.3.2 Power Supply Time Sequence	17
3.4 Signal Control Interface.....	18
3.4.1 Overview.....	18
3.4.2 WAKE# Signal	18
3.4.3 RESIN_N Signal	19
3.4.4 LED_WWAN# Signal.....	20
3.5 USB Interface	21
3.5.1 Overview.....	21
3.5.2 Circuit Recommended for the USB Interface	22
3.6 USIM Card Interface	22
3.6.1 Overview.....	22
3.6.2 Circuit Recommended for the USIM Card Interface.....	23
3.7 Audio Interface	24
3.7.1 Overview.....	24
3.7.2 Circuit Recommended for the Audio Interface	25
3.8 NC Pins	25
4 RF Specifications.....	27
4.1 About This Chapter.....	27
4.2 Operating Frequencies.....	27
4.3 Conducted RF Measurement	28
4.3.1 Test Environment.....	28
4.3.2 Test Standards	28



4.4 Conducted Rx Sensitivity and Tx Power	28
4.4.1 Conducted Receive Sensitivity	28
4.4.2 Conducted Transmit Power	29
4.5 Antenna Design Requirements	30
4.5.1 Antenna Design Indicators.....	30
4.5.2 Interference	33
4.5.3 GSM/WCDMA Antenna Requirements.....	33
5 Electrical and Reliability Features	35
5.1 About This Chapter.....	35
5.2 Absolute Ratings	35
5.3 Operating and Storage Temperatures	35
5.4 Power Supply Features	36
5.4.1 Input Power Supply	36
5.4.2 Power Consumption	37
5.5 Reliability Features.....	41
5.6 EMC and ESD Features.....	44
6 Mechanical Specifications.....	46
6.1 About This Chapter.....	46
6.2 Dimensions and Interfaces.....	46
6.3 Dimensions of the Mini PCI Express Connector	47
6.4 Packaging.....	48
6.5 Specification Selection for Fasteners	49
6.5.1 Installing the Mini PCIe Adapter on the Main Board.....	49
6.5.2 Removing the Mini PCIe Adapter from the Main Board	51
6.6 Antenna Plug	52
6.7 Thermal Design Guide	53
7 Certifications.....	56
7.1 About This Chapter.....	56
7.2 Certifications.....	56
8 Safety Information.....	57
8.1 Interference	57
8.2 Medical Device	57
8.3 Area with Inflammables and Explosives.....	57
8.4 Traffic Security.....	58
8.5 Airline Security.....	58
8.6 Safety of Children.....	58
8.7 Environment Protection	58
8.8 WEEE Approval.....	58
8.9 RoHS Approval.....	58
8.10 Laws and Regulations Observance	59



8.11 Care and Maintenance	59
8.12 Emergency Call	59
8.13 Regulatory Information	59
8.13.1 CE Approval (European Union)	59
8.13.2 FCC Statement	60
9 Appendix A Circuit of Typical Interface	61
10 Appendix B Acronyms and Abbreviations	62



1 Introduction

This document describes the hardware application interfaces and air interfaces provided by HUAWEI MU709 series (MU709s-2 and MU709s-6) HSPA+ Mini PCIe Module (hereinafter referred to as the MU709 module).

This document helps hardware engineer to understand the interface specifications, electrical features and related product information of the MU709 module.

2 Overall Description

2.1 About This Chapter

This chapter gives a general description of the MU709 module and provides:

- Function Overview
- Circuit Block Diagram

2.2 Function Overview

Table 2-1 Features

Feature	Description
Physical Dimensions	<ul style="list-style-type: none">• Dimensions: (L x W x H): 51 mm x 30.4 mm x 3.27 mm• Weight: about 12 g
Operating Bands	<ul style="list-style-type: none">• MU709s-2 WCDMA/HSDPA/HSUPA/HSPA+: Band 1, Band 8, all bands with diversity GSM/GPRS/EDGE: 850 MHz/900 MHz/1800 MHz/1900 MHz
	<ul style="list-style-type: none">• MU709s-6 WCDMA/HSDPA/HSUPA/HSPA+: Band 1, Band 2, Band 5, all bands with diversity GSM/GPRS/EDGE: 850 MHz/900 MHz/1800 MHz/1900 MHz
Operating Temperature	Normal operating temperature: -20°C to +70°C Extended operating temperature ^[1] : -30°C to +75°C
Storage Temperature	-40°C to +85°C
Humidity	RH5% to RH95%
Power Voltage	DC 3.0 V to 3.6 V (typical value is 3.3 V)

Feature	Description
AT Commands	See the HUAWEI MU709 Series HSPA+ Module AT Command Interface Specification .
Application Interface (52-pin Mini PCIe interface)	One standard USIM card (Class B and Class C)
	Audio interface: PCM interface
	USB 2.0 (High Speed)
	RESIN_N: Reset module
	WAKE#: Wake up signal
	LED_WWAN#: Active-low LED signal indicating the state of the module
Antenna connector	<ul style="list-style-type: none"> • WWAN MAIN antenna connector x1 • WWAN AUX antenna connector x1
SMS	New message alert
	Management of SMS: read SMS, write SMS, send SMS, delete SMS and list SMS
	Supports MO and MT: Point-to-point
Data Services	GPRS: UL 85.6 kbit/s; DL 85.6 kbit/s
	EDGE: UL 236.8 kbit/s; DL 236.8 kbit/s
	WCDMA PS: UL 384 kbit/s; DL 384 kbit/s
	HSPA+: UL 5.76 Mbit/s; DL 21.6 Mbit/s
Operating Systems	Android 2.x/3.x/4.x
	Linux (Kernel 2.6.18 or later)
	Windows 7/8/8.1
	Windows CE 5.0/6.0/7.0



NOTE

- [1]: When the ME909s LGA module works in the range from -30°C to -20°C or $+70^{\circ}\text{C}$ to $+75^{\circ}\text{C}$, **NOT** all their RF performances comply with 3GPP specifications.
- The thermal design must be implemented according to the chapter 6.7 Thermal Design Guide. If not, the overheat protection mechanism will be triggered due to overheated Mini PCIe and the network connection will be terminated.

2.3 Circuit Block Diagram

Figure 2-1 shows the circuit block diagram of the MU709 adapter. The major functional unit of the Mini PCIe Adapter contains the following parts:

- Power supply circuit

- LGA Module
- Control signals
- Antenna Connectors

Figure 2-1 Circuit block diagram of the MU709 module

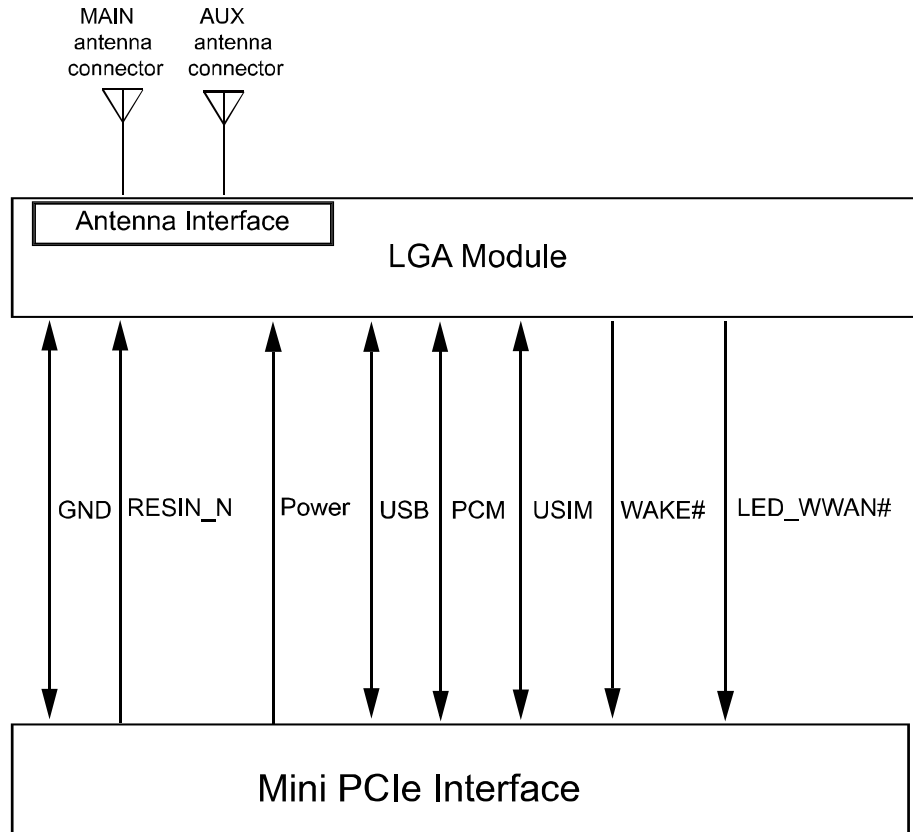

3 Description of the Application Interfaces

3.1 About This Chapter

This chapter mainly describes the external application interfaces of the MU709 module, including:

- Mini PCIe Interface
- Power Interface
- Signal Control Interface
- USB Interface
- USIM Card Interface
- Audio Interface
- NC Pins

3.2 Mini PCIe Interface

The MU709 module uses a Mini PCIe interface as its external interface. For details about the module and dimensions, see Dimensions and Interfaces.

Figure 3-1 Sequence of Mini PCIe interface

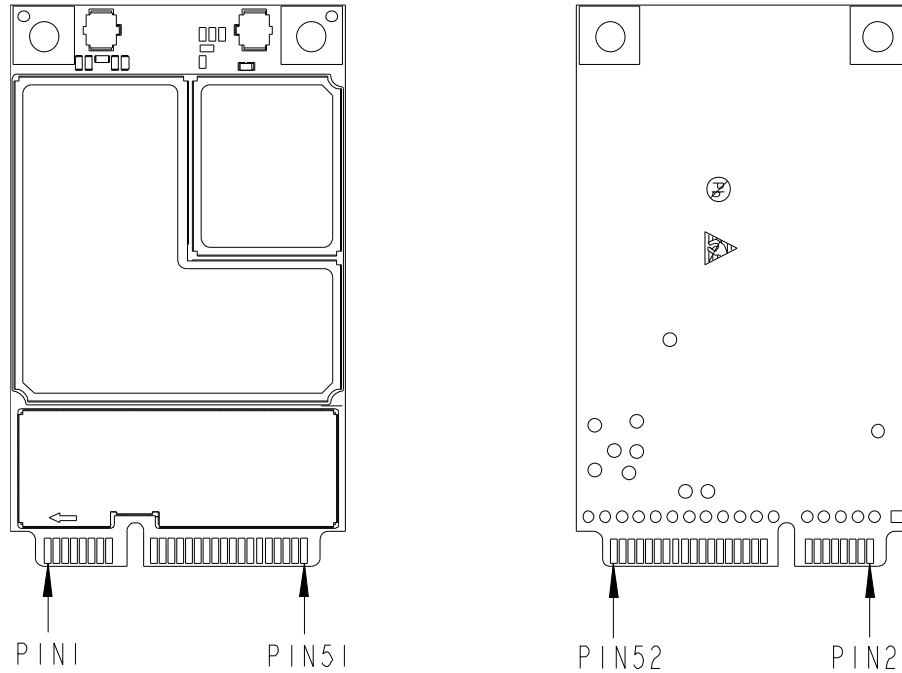

Table 3-1 Pin definitions of the Mini PCIe Interface

Pin No.	Pin Name		Pad Type	Description	Parameter	Min. (V)	Typ. (V)	Max. (V)	Comments
	Mini PCI Express Standard Description	HUAWEI Pin Description							
1	WAKE#	WAKE#	O	Open collector active low signal. This signal is used to wake up the host.	-	-0.3	-	0.45	-
2	3.3Vaux	VCC_3V3	PI	3.3 V DC supply input.	-	3.0	3.3	3.6	-
3	COEX1	NC	-	Not connected	-	-	-	-	-
4	GND	GND	-	Ground	-	-	-	-	-
5	COEX2	NC	-	Not connected	-	-	-	-	-
6	1.5 V	NC	-	Not connected	-	-	-	-	-

Pin No.	Pin Name		Pad Type	Description	Parameter	Min. (V)	Typ. (V)	Max. (V)	Comments
	Mini PCI Express Standard Description	HUAWEI Pin Description							
7	CLKREQ#	NC	-	Not connected	-	-	-	-	-
8	UIM_PWR	USIM_PWR	PO	Power source for the external USIM card	-	-0.3	1.8	1.98	USIM_PWR=1.8 V
					-	-0.3	3.0	3.3	USIM_PWR=3.0 V
9	GND	GND	-	Ground	-	-	-	-	-
10	UIM_DATA	USIM_DATA	I/O	External USIM data signal	V _{OH}	0.7 x USIM_PWR	-	3.3	USIM_PWR=1.8 V or 3.0 V
					V _{OL}	0	-	0.2 x USIM_PWR	
					V _{IH}	0.65 x USIM_PWR	-	3.30	
					V _{IL}	0	-	0.25x USIM_PWR	
11	REFCLK-	NC	-	Not connected	-	-	-	-	-
12	UIM_CLK	USIM_CLK	O	External USIM clock signal	V _{OH}	0.7 x USIM_PWR	-	3.3	USIM_PWR=1.8 V or 3.0 V
					V _{OL}	0	-	0.2 x USIM_PWR	
13	REFCLK+	NC	-	Not connected	-	-	-	-	-
14	UIM_RESET	USIM_RESET	O	External USIM reset signal	V _{OH}	0.7 x USIM_PWR	-	3.3	USIM_PWR=1.8 V or 3.0 V
					V _{OL}	0	-	0.2 x USIM_PWR	



Pin No.	Pin Name		Pad Type	Description	Parameter	Min. (V)	Typ. (V)	Max. (V)	Comments
	Mini PCI Express Standard Description	HUAWEI Pin Description							
15	GND	GND	-	Ground	-	-	-	-	-
16	UIM_Vpp	NC	-	Not connected	-	-	-	-	-
17	Reserved	NC	-	Not connected	-	-	-	-	-
18	GND	GND	-	Ground	-	-	-	-	-
19	Reserved	NC	-	Not connected	-	-	-	-	-
20	W_DISABLE #	NC	-	Not connected	-	-	-	-	-
21	GND	GND	-	Ground	-	-	-	-	-
22	RERST#	RESIN_N	I	Reset module Active-low	V _{IL}	-0.3	0	0.3	-
					V _{IH}	1.17	1.8	3.6	-
23	PERn0	NC	-	Not connected	-	-	-	-	-
24	3.3Vaux	VCC_3V3	PI	3.3 V DC supply input.	-	3.0	3.3	3.6	-
25	PERp0	NC	-	Not connected	-	-	-	-	-
26	GND	GND	-	Ground	-	-	-	-	-
27	GND	GND	-	Ground	-	-	-	-	-
28	1.5 V	NC	-	Not connected	-	-	-	-	-
29	GND	GND	-	Ground	-	-	-	-	-
30	SMB_CLK	NC	-	Not connected	-	-	-	-	-
31	PETn0	NC	-	Not connected	-	-	-	-	-
32	SMB_DATA	NC	-	Not connected	-	-	-	-	-
33	PETp0	NC	-	Not connected	-	-	-	-	-
34	GND	GND	-	Ground	-	-	-	-	-



Pin No.	Pin Name		Pad Type	Description	Parameter	Min. (V)	Typ. (V)	Max. (V)	Comments
	Mini PCI Express Standard Description	HUAWEI Pin Description							
35	GND	GND	-	Ground	-	-	-	-	-
36	USB_D-	USB_DM	I/O	USB signal D-	-	-	-	-	-
37	GND	GND	-	Ground	-	-	-	-	-
38	USB_D+	USB_DP	I/O	USB signal D+	-	-	-	-	-
39	3.3Vaux	VCC_3V3	PI	3.3 V DC supply input.	-	3.0	3.3	3.6	-
40	GND	GND	-	Ground	-	-	-	-	-
41	3.3Vaux	VCC_3V3	PI	3.3 V DC supply input.	-	3.0	3.3	3.6	-
42	LED_WWAN #	LED_WWAN #	O	Active-low LED signal indicating the state of the card.	V _{OL}	-0.3	-	0.45	-
43	GND	GND	-	Ground	-	-	-	-	-
44	LED_WLAN #	NC	-	Not connected	-	-	-	-	-
45	Reserved	PCM_CLK	O	PCM interface clock	V _{OL}	-0.3	0	0.45	-
					V _{OH}	1.35	1.8	2.1	-
46	LED_WPAN #	NC	-	Not connected	-	-	-	-	-
47	Reserved	PCM_DOUT	O	PCM I/F data output	V _{OL}	-0.3	0	0.45	-
					V _{OH}	1.35	1.8	2.1	-
48	1.5 V	NC	-	Not connected	-	-	-	-	-
49	Reserved	PCM_DIN	I	PCM I/F data input	V _{IL}	-0.3	0	0.63	-
					V _{IH}	1.17	1.8	2.1	-
50	GND	GND	-	Ground	-	-	-	-	-
51	Reserved	PCM_SYNC	O	PCM interface sync	V _{OL}	-0.3	0	0.45	-
					V _{OH}	1.35	1.8	2.1	-

Pin No.	Pin Name		Pad Type	Description	Parameter	Min. (V)	Typ. (V)	Max. (V)	Comments
	Mini PCI Express Standard Description	HUAWEI Pin Description							
52	3.3Vaux	VCC_3V3	PI	3.3 V DC supply input	-	3.0	3.3	3.6	-



NOTE

- **P** indicates power pins; **I** indicates pins for digital signal input; **O** indicates pins for digital signal output; **PO** indicates power output pins; **PI** indicates power input pins.
- **V_{IL}** indicates Low-level Input voltage; **V_{IH}** indicates High-level Input voltage; **V_{OL}** indicates Low-level Output voltage; **V_{OH}** indicates High-level Output voltage.
- The **NC** pins are floating and there are no signal connected to these pins. Therefore, these pins should not be used.

3.3 Power Interface

3.3.1 Sources and Grounds

For the Mini PCIe Adapter, +3.3Vaux is the only voltage supply that is available. The input voltage is 3.3 V \pm 9%, as specified by [PCI Express Mini Card Electromechanical Specification Revision 1.2](#).

Table 3-2 Power and ground specifications

Pin No.	Pin Name	Pad Type	Description	Min.(V)	Typ.(V)	Max.(V)
2, 24, 39, 41 and 52	VCC_3V3	PI	3.3 V DC supply input	3.0	3.3	3.6
4, 9, 15, 18, 21, 26, 27, 29, 34, 35, 37, 40, 43 and 50	GND	-	Ground	-	-	-



NOTE

To minimize the RF radiation through the power lines, it is suggested to add ceramic capacitors of 10 pF and 100 nF in the power lines beside the Mini PCIe connector on the host side.

3.3.2 Power Supply Time Sequence

Power on Sequence

Figure 3-2 Power on timing sequence

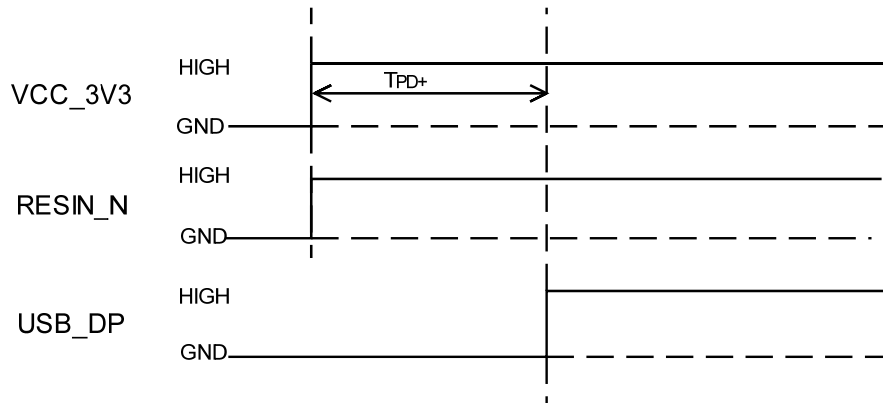

Parameter	Remarks	Time (Nominal value)	Unit
T _{PD+}	Power Valid to USB D+ high	7.0	s



NOTE

Do not toggle RESIN_N pin during the power on sequence. Pull-Down RESIN_N pin will extend time for module startup.

Power off Sequence

Cutting off the VCC_3V3 power supply will power off the module.

Figure 3-3 Power off timing sequence

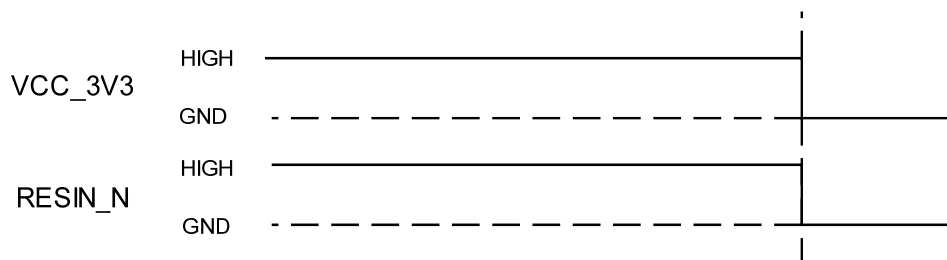

3.4 Signal Control Interface

3.4.1 Overview

The signal control part of the interface in the MU709 module consists of the following:

- WAKE# Signal
- RESIN_N Signal
- LED_WWAN# Signal

Table 3-3 Definitions of the pins on the signal control interface

Pin No.	Pin Name	Pad Type	Description	Parameter	Min. (V)	Typ. (V)	Max. (V)
1	WAKE#	O	Open collector active low signal. This signal is used to wake up the host.	-	-0.3	-	0.45
22	RESIN_N	I	Reset module Active-low	V _{IL}	-0.3	0	0.3
				V _{IH}	1.17	1.8	3.6
42	LED_WWAN#	O	Active-low LED signal indicating the state of the card.	V _{OL}	-0.3	-	0.45

3.4.2 WAKE# Signal

WAKE# signal supports software control.

This signal is used for module to wake up the host. It is designed as an OC (Open Collector) gate, so it should be pulled up by the host and it is active-low.

When the module wakes up the host, the WAKE# pin will output low-level-voltage for 1s to wake up the host.

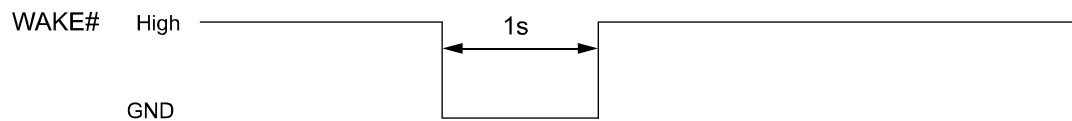
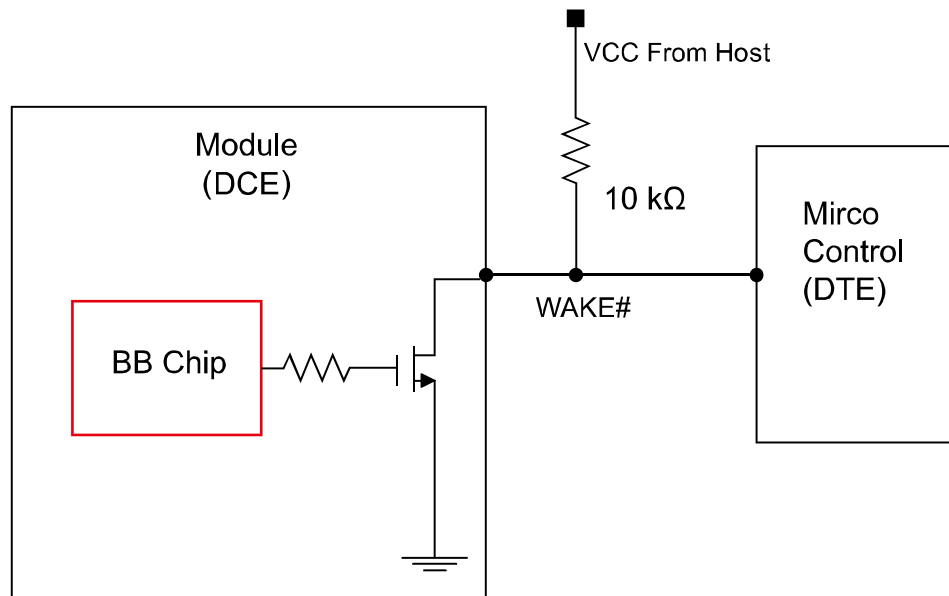

Figure 3-4 Connections of the WAKE# pin



3.4.3 RESIN_N Signal

The RESIN_N signal is used to reset the module's system. When the module software stops responding, the RESIN_N pin can be pulled down to reset the module hardware.

The RESIN_N signal is internally pulled up to 1.8 V, and it turns on automatically when the VCC_3V3 is pulled up. The RESIN_N signal is active-low.

Figure 3-5 Connections of the RESIN_N pin

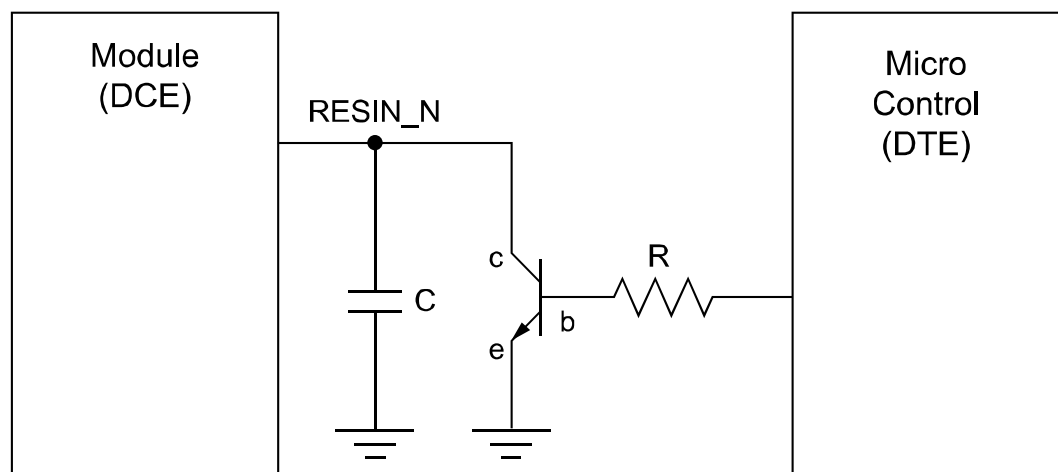

 **CAUTION**

- As the RESIN_N signal is relatively sensitive, it is recommended that you install a 10 nF–0.1 μF capacitor near the RESIN_N pin of the interface for filtering. In addition, when you design a circuit on the PCB of the interface board, it is recommended that the circuit length should not exceed 20 mm and that the circuit should be kept at a distance of 2.54 mm (100 mil) at least from the PCB edge. Furthermore, you need to wrap the area adjacent to the signal wire with a ground wire. Otherwise, the module may be reset due to interference.
- The maximum Forward Voltage Drop of the diode used in the module is 0.6 V. So when the host wants to reset the module, the low-level-voltage in the RESIN_N pin should be below 50 mV.

The MU709 module supports hardware reset function. If the software of the MU709 module stops responding, you can reset the hardware through the RESIN_N signal as shown in Figure 3-6 . When a low-level pulse is supplied through the RESIN_N pin, the hardware will be reset. After the hardware is reset, the software starts powering on the module and reports relevant information according to the actual settings. For example, the AT command automatically reports ^SYSSTART.

Figure 3-6 Reset pulse timing

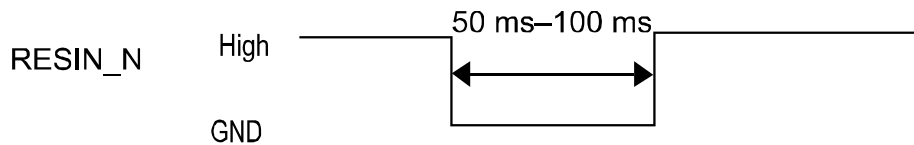

 **NOTE**

- The RESIN_N pin must not be pulled down for more than 1s.
- The RESIN_N pin is optional, which can not be connected.

3.4.4 LED_WWAN# Signal

MU709 series module provides an LED_WWAN# signal to indicate the work status.

This function is disabled by default, it is controlled by AT^LEDCTRL. For details about the command, please refer to [HUAWEI MU709 Series HSPA+ Module AT Command Interface Specification](#).

Table 3-4 State of the LED_WWAN# pin

No.	Operating Status	LED_WWAN#
1	No service or Restricted service	Outputs: low (0.1s)-high (0.1s)-low (0.1s)-high (1.7s) 2s cycle
2	Register to the network	Outputs: low (0.1s)-high (1.9s) 2s cycle
3	Dial-up successfully	Outputs: low

Figure 3-7 shows the recommended circuits of the LED_WWAN# pin. According to LED feature, you can adjust the LED brightness by adjusting the resistance of resistor R.

Figure 3-7 Driving circuit

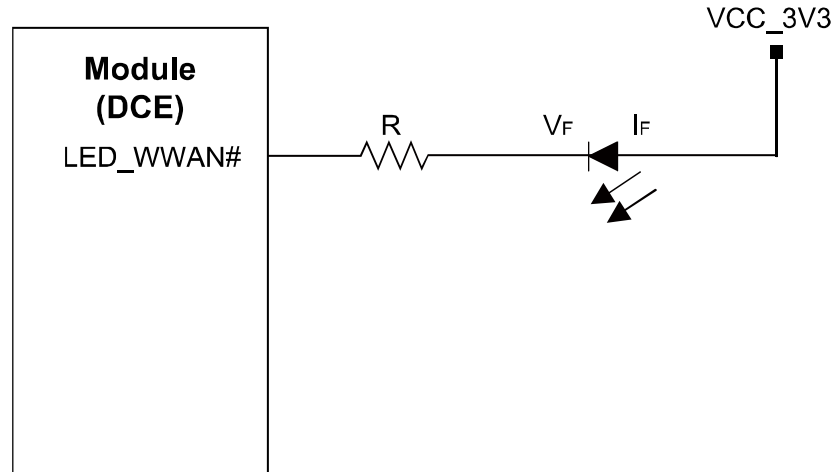

3.5 USB Interface

3.5.1 Overview

The MU709 module is compliant with USB 2.0 protocol. The USB interface is powered directly from the VBAT supply. The USB input/output lines are compatible with the USB 2.0 signal specifications. Figure 3-8 shows the circuit of the USB interface.

Table 3-5 Definition of the USB interface

Pin No.	Pin Name	Pad Type	Description	Parameter	Min.(V)	Typ.(V)	Max.(V)
36	USB_DM	I/O	USB signal D-	-	-	-	-
38	USB_DP	I/O	USB signal D+	-	-	-	-

According to USB protocol, for bus timing or electrical characteristics of MU709 USB signal, please refer to the chapter 7.3.2 of [Universal Serial Bus Specification 2.0](#).

3.5.2 Circuit Recommended for the USB Interface

Figure 3-8 Recommended circuit of USB interface



3.6 USIM Card Interface

3.6.1 Overview

The MU709 module provides a USIM card interface complying with the ISO 7816-3 standard and supports both Class B and Class C USIM cards.

Table 3-6 USIM card interface signals

PIN No.	Pin Name	Pad Type	Description	Parameter	Min. (V)	Typ. (V)	Max. (V)	Comments
14	USIM_RESET	O	External USIM reset signal	V_{OH}	0.7 x USIM_PWR	-	3.3	USIM_PWR=1.8 V or 3.0 V
				V_{OL}	0	-	0.2 x USIM_PWR	
12	USIM_CLK	O	External USIM clock signal	V_{OH}	0.7 x USIM_PWR	-	3.3	USIM_PWR=1.8 V or 3.0 V
				V_{OL}	0	-	0.2 x USIM_PWR	
10	USIM_DATA	I/O	External USIM data signal	V_{IH}	0.7 x USIM_PWR	-	3.3	USIM_PWR=1.8 V or 3.0 V
				V_{IL}	0	-	0.2 x USIM_PWR	
				V_{OH}	0.65 x USIM_PWR	-	3.3	
				V_{OL}	0	-	0.25 x USIM_PWR	

PIN No.	Pin Name	Pad Type	Description	Parameter	Min. (V)	Typ. (V)	Max. (V)	Comments
8	USIM_PWR	PO	Power source for the external USIM card	-	-0.3	1.8	1.98	USIM_PWR=1.8 V
				-	-0.3	3.0	3.3	USIM_PWR=3.0 V

3.6.2 Circuit Recommended for the USIM Card Interface

As the Mini PCIe Adapter is not equipped with a USIM socket, you need to place a USIM socket on the user interface board. Figure 3-9 shows the circuit of the USIM card interface.

Figure 3-9 Circuit of the USIM card interface

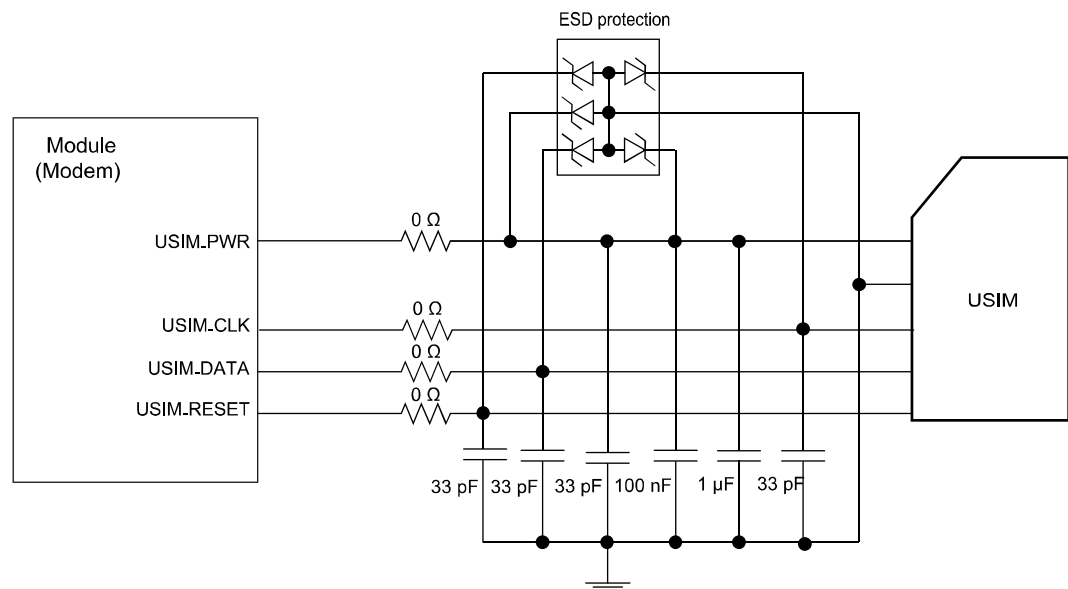

CAUTION

- To meet the requirements of 3GPP TS 51.010-1 protocols and electromagnetic compatibility (EMC) authentication, the USIM socket should be placed near the PCIe interface (it is recommended that the PCB circuit connects the PCIe interface and the USIM socket does not exceed 100 mm), because a long circuit may lead to wave distortion, thus affecting signal quality.
- It is recommended that you wrap the area adjacent to the USIM_CLK and USIM_DATA signal wires with ground. The Ground pin of the USIM socket and the Ground pin of the USIM card must be well connected to the power Ground pin supplying power to the PCIe Adapter.
- A 100 nF capacitor and 1 μF capacitor are placed between the USIM_PWR and Ground pins in a parallel manner (If USIM_PWR circuit is too long, that the larger capacitance such as 4.7 μF can be employed if necessary). Three 33 pF

capacitors are placed between the USIM_DATA and Ground pins, the USIM_RESET and Ground pins, and the USIM_CLK and Ground pins in parallel to filter interference from RF signals.

- It is recommended to take electrostatic discharge (ESD) protection measures near the USIM card socket. The TVS diode with Vrwm of 5 V and junction capacitance less than 10 pF must be placed as close as possible to the USIM socket, and the Ground pin of the ESD protection component is well connected to the power Ground pin that supplies power to the PCIe Adapter.

3.7 Audio Interface

3.7.1 Overview

The MU709 module provides one PCM digital audio interface. Table 3-7 lists the signals on the digital audio interface.

Table 3-7 Signals on the digital audio interface

Pin No.	Pin Name	Pad Type	Description	Parameter	Min.(V)	Typ.(V)	Max.(V)
45	PCM_CLK	O	PCM clock	V _{OL}	-0.3	0	0.45
				V _{OH}	1.35	1.8	2.1
47	PCM_DOUT	O	PCM I/F data output	V _{OL}	-0.3	0	0.45
				V _{OH}	1.35	1.8	2.1
49	PCM_DIN	I	PCM I/F data input	V _{IL}	-0.3	0	0.63
				V _{IH}	1.17	1.8	2.1
51	PCM_SYNC	O	PCM interface sync	V _{OL}	-0.3	0	0.45
				V _{OH}	1.35	1.8	2.1

The MU709 module interface enables communication with an external codec to support linear format.

3.7.2 Circuit Recommended for the Audio Interface

Figure 3-10 Circuit diagram of the interface of the PCM (MU709 module is used as PCM master)

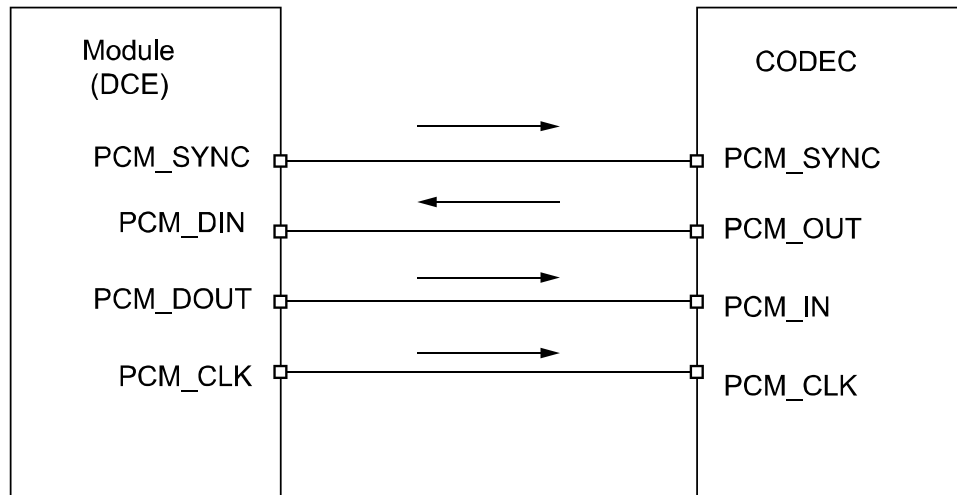
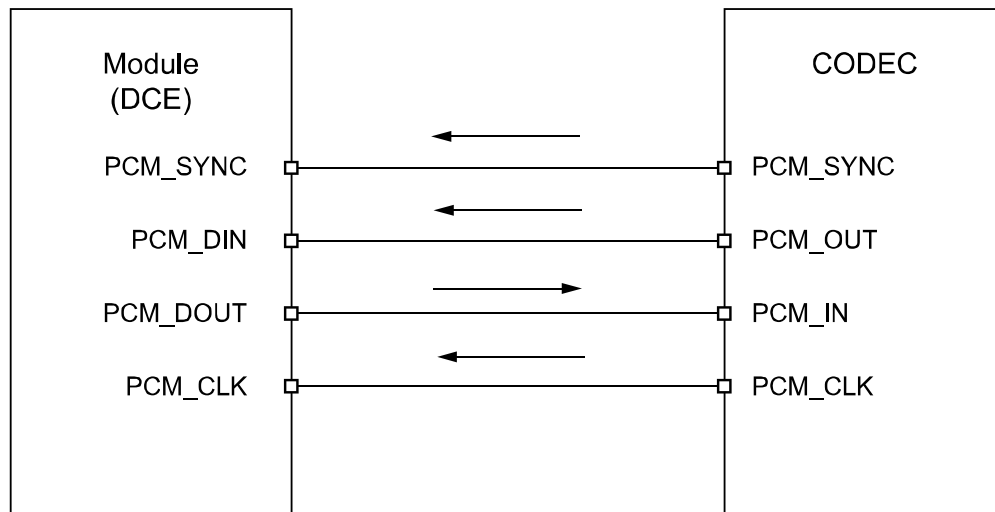

Figure 3-11 Circuit diagram of the interface of the PCM (MU709 is used as PCM slave)



NOTE

- MU709 module supports both master and slave mode.
- PCM_SYNC and PCM_CLK: Output when PCM is in master mode; Input when PCM is in slave mode.
- It is recommended that a TVS be used on the related interface, to prevent electrostatic discharge and protect integrated circuit (IC) components.

3.8 NC Pins

The MU709 module has some NC pins. All of NC pins should not be connected. Please keep these pins open.

Table 3-8 NC pins

Pin No.	Pin Name	Pad Type	Description	Parameter	Min.(V)	Typ.(V)	Max.(V)
3, 5–7, 11, 13, 16, 17, 19, 20, 23, 25, 28, 30–33, 44, 46 and 48	NC	-	Not connected, please keep open.	-	-	-	-

4 RF Specifications

4.1 About This Chapter

This chapter describes the RF specifications of the MU709 module, including:

- Operating Frequencies
- Conducted RF Measurement
- Conducted Rx Sensitivity and Tx Power
- Antenna Design Requirements

4.2 Operating Frequencies

Table 4-1 and Table 4-2 show the RF bands supported by the MU709 module.

Table 4-1 RF bands of the MU709s-2 module

Operating Band	Tx	Rx
UMTS Band 1	1920 MHz–1980 MHz	2110 MHz–2170 MHz
UMTS Band 8	880 MHz–915 MHz	925 MHz–960 MHz
GSM 850	824 MHz–849 MHz	869 MHz–894 MHz
GSM 900	880 MHz–915 MHz	925 MHz–960 MHz
GSM 1800 (DCS)	1710 MHz–1785 MHz	1805 MHz–1880 MHz
GSM 1900 (PCS)	1850 MHz–1910 MHz	1930 MHz–1990 MHz

Table 4-2 RF bands of MU709s-6 module

Operating Band	Tx	Rx
UMTS Band 1	1920 MHz–1980 MHz	2110 MHz–2170 MHz
UMTS Band 2	1850 MHz–1910 MHz	1930 MHz–1990 MHz

Operating Band	Tx	Rx
UMTS Band 5	824 MHz–849 MHz	869 MHz–894 MHz
GSM 850	824 MHz–849 MHz	869 MHz–894 MHz
GSM 900	880 MHz–915 MHz	925 MHz–960 MHz
GSM 1800 (DCS)	1710 MHz–1785 MHz	1805 MHz–1880 MHz
GSM 1900 (PCS)	1850 MHz–1910 MHz	1930 MHz–1990 MHz

4.3 Conducted RF Measurement

4.3.1 Test Environment

Test instrument	R&S CMU200
Power supply	KEITHLEY 2306
RF cable for testing	L08-C014-350 of DRAKA COMTEQ or Rosenberger Cable length: 29 cm



NOTE

- The compensation for different frequency bands relates to the cable and the test environment.
- The instrument compensation needs to be set according to the actual cable conditions.

4.3.2 Test Standards

Huawei modules meet 3GPP test standards. Each module passes strict tests at the factory and thus the quality of the modules is guaranteed.

4.4 Conducted Rx Sensitivity and Tx Power

4.4.1 Conducted Receive Sensitivity

The conducted receive sensitivity is a key parameter that indicates the receiver performance of MU709 module. The conducted receive sensitivity refers to the weakest signal that the module at the antenna port can receive. Table 4-3 and Table 4-4 list the typical tested values of the MU709 module.

Table 4-3 MU709s-2 module conducted Rx sensitivity

Band	Typical value (Unit: dBm)	Note
GSM 850	-109.5	BER Class II < 2.44%

Band	Typical value (Unit: dBm)	Note
GSM 900	-109	BER Class II < 2.44%
GSM 1800 (DCS)	-108	BER Class II < 2.44%
GSM 1900 (PCS)	-108	BER Class II < 2.44%
WCDMA Band 1	-109	BER < 0.1%
WCDMA Band 8	-110	BER < 0.1%

Table 4-4 MU709s-6 module conducted Rx sensitivity

Band	Test Value (Unit: dBm)	Note
GSM 850	-109.5	BER Class II < 2.44%
GSM 900	-109	BER Class II < 2.44%
GSM 1800 (DCS)	-108	BER Class II < 2.44%
GSM 1900 (PCS)	-108	BER Class II < 2.44%
WCDMA Band 1	-109	BER < 0.1%
WCDMA Band 2	-110.5	BER < 0.1%
WCDMA Band 5	-111.5	BER < 0.1%



NOTE

The test values are the average of some test samples.

4.4.2 Conducted Transmit Power

The conducted transmit power is another indicator that measures the performance of MU709 module. The conducted transmit power refers to the maximum power that the module tested at the antenna connector can transmit. According to the 3GPP protocol, the required transmit power varies with the power class. Table 4-5 and Table 4-6 list the typical tested values of the MU709 module.

Table 4-5 MU709s-2 module conducted Tx power

Band		Typical Value (Unit: dBm)	Note (Unit: dB)
GSM 850	GMSK(1Tx Slot)	32	±1.5
	8PSK(1Tx Slot)	26.5	±2
GSM 900	GMSK(1Tx Slot)	32	±1.5
	8PSK(1Tx Slot)	26.5	±2
GSM 1800	GMSK(1Tx Slot)	29	±1.5

Band		Typical Value (Unit: dBm)	Note (Unit: dB)
(DCS)	8PSK(1Tx Slot)	25	±2
GSM 1900 (PCS)	GMSK(1Tx Slot)	29	±1.5
	8PSK(1Tx Slot)	25	±2
WCDMA Band 1		23	±1
WCDMA Band 8		23	-1.5/+1

Table 4-6 MU709s-6 module conducted Tx power

Band		Typical Value (Unit: dBm)	Note (Unit: dB)
GSM 850	GMSK(1Tx Slot)	32	±1.5
	8PSK(1Tx Slot)	26.5	±2
GSM 900	GMSK(1Tx Slot)	32	±1.5
	8PSK(1Tx Slot)	26.5	±2
GSM 1800 (DCS)	GMSK(1Tx Slot)	29	±1.5
	8PSK(1Tx Slot)	25	±2
GSM 1900 (PCS)	GMSK(1Tx Slot)	29	±1.5
	8PSK(1Tx Slot)	25	±2
WCDMA Band 1		23	±1
WCDMA Band 2		23	±1
WCDMA Band 5		23	-1.5/+1

4.5 Antenna Design Requirements

4.5.1 Antenna Design Indicators

Antenna Efficiency

Antenna efficiency is the ratio of the input power to the radiated or received power of an antenna. The radiated power of an antenna is always lower than the input power due to the following antenna losses: return loss, material loss, and coupling loss. The efficiency of an antenna relates to its electrical dimensions. To be specific, the antenna efficiency increases with the electrical dimensions. In addition, the transmission cable from the antenna connector of PCIe Adapter to the antenna is also part of the antenna. The cable loss increases with the cable length and the frequency.

It is recommended that the cable loss is as low as possible, for example, U.FL-LP-088 made by HRS.

The following antenna efficiency (free space) is recommended for MU709 module to ensure high radio performance of the module:

- **Efficiency of the primary antenna: $\geq 40\%$ (below 960 MHz); $\geq 50\%$ (over 1710 MHz)**
- **Efficiency of the diversity antenna: \geq half of the efficiency of the primary antenna in receiving band**

In addition, the efficiency should be tested with the transmission cable.

S11 or VSWR

S11 indicates the degree to which the input impedance of an antenna matches the reference impedance (50Ω). S11 shows the resonance feature and impedance bandwidth of an antenna. Voltage standing wave ratio (VSWR) is another expression of S11. S11 relates to the antenna efficiency. S11 can be measured with a vector analyzer.

The following S11 value is recommended for the antenna of MU709 module:

- **S11 of the primary antenna: ≤ -6 dB**
- **S11 of the diversity antenna: ≤ -6 dB**

In addition, S11 is less important than the efficiency, and S11 has weak correlation to wireless performance.

Isolation

For a wireless device with multiple antennas, the power of different antennas is coupled with each other. Antenna isolation is used to measure the power coupling. The power radiated by an antenna might be received by an adjacent antenna, which decreases the antenna radiation efficiency and affects the running of other devices. To avoid this problem, evaluate the antenna isolation as sufficiently as possible at the early stage of antenna design.

Antenna isolation depends on the following factors:

- Distance between antennas
- Antenna type
- Antenna direction

The primary antenna must be placed as near as possible to the MU709 module to minimize the cable length. The diversity antenna needs to be installed perpendicularly to the primary antenna. The diversity antenna can be placed farther away from the MU709 module. Antenna isolation can be measured with a two-port vector network analyzer.

The following antenna isolation is recommended for the antennas on laptops:

- **Isolation between the primary and diversity antennas: ≤ -12 dB**
- **Isolation between the primary antenna and the Wi-Fi antenna: ≤ -15 dB**

Polarization

The polarization of an antenna is the orientation of the electric field vector that rotates with time in the direction of maximum radiation.

The linear polarization is recommended for the antenna of MU709 module.

Radiation Pattern

The radiation pattern of an antenna reflects the radiation features of the antenna in the remote field region. The radiation pattern of an antenna commonly describes the power or field strength of the radiated electromagnetic waves in various directions from the antenna. The power or field strength varies with the angular coordinates (θ and ϕ), but is independent of the radial coordinates.

The radiation pattern of half wave dipole antennas is omnidirectional in the horizontal plane, and the incident waves of base stations are often in the horizontal plane. For this reason, the receiving performance is optimal.

The following radiation patterns are recommended for the antenna of MU709 module.

Primary/Diversity antenna: omnidirectional

In addition, the diversity antenna's pattern should be complementary with the primary's.

Envelope Correlation Coefficient

The envelope correlation coefficient indicates the correlation between different antennas in a multi-antenna system (primary antenna, diversity antenna, and MIMO antenna). The correlation coefficient shows the similarity of radiation patterns, that is, amplitude and phase, of the antennas. The ideal correlation coefficient of a diversity antenna system or a MIMO antenna system is 0. A small value of the envelope correlation coefficient between the primary antenna and the diversity antenna indicates a high diversity gain. The envelope correlation coefficient depends on the following factors:

- Distance between antennas
- Antenna type
- Antenna direction

The antenna correlation coefficient differs from the antenna isolation. Sufficient antenna isolation does not represent a satisfactory correlation coefficient. For this reason, the two indicators need to be evaluated separately.

For the antennas on laptops, the recommended envelope correlation coefficient between the primary antenna and the diversity antenna is smaller than 0.5.

Gain and Directivity

The radiation pattern of an antenna represents the field strength of the radiated electromagnetic waves in all directions, but not the power density that the antenna radiates in the specific direction. The directivity of an antenna, however, measures the power density that the antenna radiates.

Antenna Requirements	
Impedance	50 Ω
VSWR absolute max	$\leq 3:1$
VSWR recommended	$\leq 2:1$

Table 4-8 MU709s-6 module antenna requirements

Antenna Requirements	
Frequency range	Depending on frequency band(s) provided by the network operator, the customer must use the most suitable antenna for that/those band(s)
Bandwidth of primary antenna	70 MHz in GSM 850 80 MHz in GSM 900 170 MHz in GSM 1800 140 MHz in GSM 1900 70 MHz in WCDMA Band 5 140 MHz in WCDMA Band 2 250 MHz in WCDMA Band 1
Bandwidth of secondary antenna	25 MHz in WCDMA Band 5 60 MHz in WCDMA Band 2 60 MHz in WCDMA Band 1
Gain	≤ 2.5 dBi
Impedance	50 Ω
VSWR absolute max	$\leq 3:1$
VSWR recommended	$\leq 2:1$

5 Electrical and Reliability Features

5.1 About This Chapter

This chapter describes the electrical and reliability features of the interfaces in the MU709 module, including:

- Absolute Ratings
- Operating and Storage Temperatures
- Power Supply Features
- Reliability Features
- EMC and ESD Features

5.2 Absolute Ratings



WARNING

Table 5-1 lists the absolute ratings for the MU709 module. Using the module beyond these conditions may result in permanent damage to the module.

Table 5-1 Absolute ratings for the MU709 module

Symbol	Specification	Min.	Max.	Unit
VCC_3V3	External power voltage	-0.3	4.0	V
VI	Digital input voltage	-0.3	2.1	V

5.3 Operating and Storage Temperatures

Table 5-2 lists the operating and storage temperatures for the MU709 module.

Table 5-2 Operating and storage temperatures for the MU709 module

Specification	Min.	Max.	Unit
Normal working temperatures	-20	+70	°C
Extended temperatures	-30	+75	°C
Ambient temperature for storage	-40	+85	°C

 **NOTE**

- [1]: When the ME909s LGA module works in the range from -30°C to -20°C or +70°C to +75°C, **NOT** all their RF performances comply with 3GPP specifications.
- The thermal design must be implemented according to the chapter 6.7 Thermal Design Guide. If not, the overheat protection mechanism will be triggered due to overheated Mini PCIe and the network connection will be terminated.

5.4 Power Supply Features

5.4.1 Input Power Supply

Table 5-3 Requirements for input power for the MU709 module

Parameter	Min.	Typ.	Max.	Ripple	Unit
VCC_3V3	3.0	3.3	3.6	0.05	V

Figure 5-1 Power Supply During Burst Emission

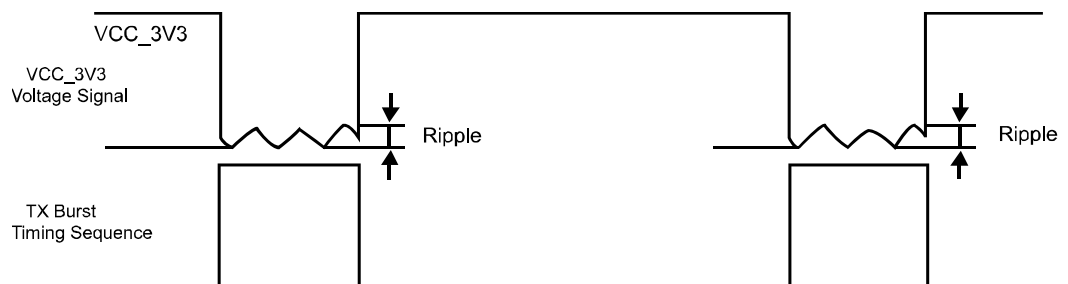

 **NOTE**

The VCC_3V3 minimum value must be guaranteed during the burst (with 2.7 A Peak in GSM 2 slot mode). So a low-dropout (LDO) regulator or switch power with current output of more than 3.5 A is strongly recommended for external power supply.

Table 5-4 Requirements for input current of the MU709 module

Power	Module	Peak (GSM 2 slot)	Normal (WCDMA)
VCC_3V3	MU709	2750 mA	1100 mA

5.4.2 Power Consumption

The power consumptions of MU709 module in different scenarios are respectively listed in Table 5-5 to Table 5-8 .

The power consumption listed in this section is tested when the power supply of the MU709 module is 3.3 V, and all of test values are measured at room temperature.

Table 5-5 Averaged standby DC power consumption of MU709 module

Description		Bands	Test Value (Unit: mA)	Notes/Configuration
			Typical	
Sleep	HSPA+/WCDMA	UMTS bands	3.1	Module is powered up. DRX cycle=7 (1.28s) Module is registered on the network. USB is in suspend.
	GPRS/EDGE	GSM bands	2.8	Module is powered up. MFRMS=5 (1.175s) Module is registered on the network. USB is in suspend.
	Radio Off	All bands	1.6	Module is powered up. RF is disabled USB is in suspend.
Idle	HSPA+/WCDMA	UMTS bands	50	Module is powered up. DRX cycle=7 (1.28s) Module is registered on the network, no data is transmitted. USB is in active.
	GPRS/EDGE	GSM bands	50	Module is powered up. MFRMS=5 (1.175s) Module is registered on the network, no data is transmitted. USB is in active.
	Radio Off	All bands	50	Module is powered up. RF is disabled. USB is in active.

Table 5-6 Averaged data transmission DC power consumption of MU709s-2 module (HSPA/WCDMA)

Description	Band	Test Value (Unit: mA)	Power
		Typical	
WCDMA	Band 1 (IMT2100)	250	0 dBm Tx Power
		320	10 dBm Tx Power
		720	23.5 dBm Tx Power
	Band 8 (900 MHz)	250	0 dBm Tx Power
		320	10 dBm Tx Power
		720	23.5dBm Tx Power
HSPA	Band 1 (IMT2100)	270	0 dBm Tx Power
		340	10 dBm Tx Power
		720	23.5 dBm Tx Power
	Band 8 (900 MHz)	270	0 dBm Tx Power
		360	10 dBm Tx Power
		740	23.5 dBm Tx Power

Table 5-7 Averaged data transmission DC power consumption of MU709s-6 module (HSPA/WCDMA)

Description	Band	Test Value (Unit: mA)	Power (dBm)
WCDMA	Band 1 (IMT 2100)	192	0 dBm Tx Power
		237	10 dBm Tx Power
		652	23.5 dBm Tx Power
	Band 2 (1900 MHz)	191	0 dBm Tx Power
		245	10 dBm Tx Power
		688	23.5 dBm Tx Power
	Band 5 (850 MHz)	182	0 dBm Tx Power
		219	10 dBm Tx Power
		562	23.5 dBm Tx Power
HSPA	Band 1 (IMT 2100)	202	0 dBm Tx Power
		255	10 dBm Tx Power
		629	23.5 dBm Tx Power

Description	Band	Test Value (Unit: mA)	Power (dBm)
	Band 2 (1900 MHz)	210	0 dBm Tx Power
		274	10 dBm Tx Power
		703	23.5 dBm Tx Power
	Band 5 (850 MHz)	197	0 dBm Tx Power
		234	10 dBm Tx Power
		552	23.5 dBm Tx Power

Table 5-8 Averaged data transmission DC power consumption of MU709 module (GPRS/EDGE)

Description	Test Value (Unit: mA)	PCL	Configuration
	Typical		
GPRS 850	250	5	1 Up/1 Down
	370		2 Up/1 Down
	510		4 Up/1 Down
	120	10	1 Up/1 Down
	200		2 Up/1 Down
	330		4 Up/1 Down
GPRS 900	250	5	1 Up/1 Down
	370		2 Up/1 Down
	520		4 Up/1 Down
	120	10	1 Up/1 Down
	200		2 Up/1 Down
	330		4 Up/1 Down
GPRS 1800	200	0	1 Up/1 Down
	280		2 Up/1 Down
	400		4 Up/1 Down
	80	10	1 Up/1 Down
	115		2 Up/1 Down
	160		4 Up/1 Down
GPRS 1900	190	0	1 Up/1 Down

Description	Test Value (Unit: mA)	PCL	Configuration
	Typical		
	260		2 Up/1 Down
	370		4 Up/1 Down
	80	10	1 Up/1 Down
	110		2 Up/1 Down
	160		4 Up/1 Down
EDGE 850	190	8	1 Up/1 Down
	290		2 Up/1 Down
	490		4 Up/1 Down
	100	15	1 Up/1 Down
	145		2 Up/1 Down
	235		4 Up/1 Down
EDGE 900	190	8	1 Up/1 Down
	290		2 Up/1 Down
	490		4 Up/1 Down
	100	15	1 Up/1 Down
	150		2 Up/1 Down
	240		4 Up/1 Down
EDGE 1800	160	2	1 Up/1 Down
	255		2 Up/1 Down
	415		4 Up/1 Down
	100	10	1 Up/1 Down
	140		2 Up/1 Down
	220		4 Up/1 Down
EDGE 1900	160	2	1 Up/1 Down
	255		2 Up/1 Down
	415		4 Up/1 Down
	100	10	1 Up/1 Down
	140		2 Up/1 Down
	220		4 Up/1 Down

 **NOTE**

- All power consumption test configuration can be referenced by GSM Association Official Document TS.09: Battery Life Measurement and Current Consumption Technique.
- Test condition: For Max. Tx. power, see 4.4.2 Conducted Transmit Power, which are listed in Table 4-5 ; for Max. data throughput, see 2.2 Function Overview, which are listed in Table 2-1 .

5.5 Reliability Features

Table 5-9 lists the test conditions and results of the reliability of the MU709 module.

Table 5-9 Test conditions and results of the reliability of the MU709 module

Item		Test Condition	Standard	Sample size	Results
Stress	Low-temperature storage	<ul style="list-style-type: none"> • Temperature: -40°C • Operation mode: no power, no package • Test duration: 24 h 	JESD22-A119-C	3 pcs/group	Visual inspection: ok Function test: ok RF specification: ok
	High-temperature storage	<ul style="list-style-type: none"> • Temperature: 85°C • Operation mode: no power, no package • Test duration: 24 h 	JESD22-A103-C	3 pcs/group	Visual inspection: ok Function test: ok RF specification: ok
	Low-temperature operating	<ul style="list-style-type: none"> • Temperature: -30°C • Operation mode: working with service connected • Test duration: 24 h 	IEC60068-2-1	3 pcs/group	Visual inspection: ok Function test: ok RF specification: ok
	High-temperature operating	<ul style="list-style-type: none"> • Temperature: 70°C • Operation mode: working with service connected • Test duration: 24 h 	JESD22-A108-C	3 pcs/group	Visual inspection: ok Function test: ok RF specification: ok
	Damp heat cycling	<ul style="list-style-type: none"> • High temperature: 55°C • Low temperature: 25°C • Humidity: 95%±3% • Operation mode: working with service connected • Test duration: 6 cycles; 12 h+12 h/cycle 	JESD22-A101-B	3 pcs/group	Visual inspection: ok Function test: ok RF specification: ok



Item	Test Condition	Standard	Sample size	Results
Thermal shock	<ul style="list-style-type: none">• Low temperature: -40°C• High temperature: 85°C• Temperature change interval: < 20s• Operation mode: no power• Test duration: 100 cycles; 15 Min+15 Min/cycle	JESD22-A106-B	3 pcs/group	Visual inspection: ok Function test: ok RF specification: ok
Salty fog test	<ul style="list-style-type: none">• Temperature: 35°C• Density of the NaCl solution: 5%±1%• Operation mode: no power, no package• Test duration: Spraying interval: 8 h Exposing period after removing the salty fog environment: 16 h	JESD22-A107-B	3 pcs/group	Visual inspection: ok Function test: ok RF specification: ok
Sine vibration	<ul style="list-style-type: none">• Frequency range: 5 Hz to 200 Hz• Acceleration: 1 Grms• Frequency scan rate: 0.5oct/min• Operation mode: working with service connected• Test duration: 3 axial directions. 2 h for each axial direction	JESD22-B103-B	3 pcs/group	Visual inspection: ok Function test: ok RF specification: ok
Shock test	<ul style="list-style-type: none">• Half-sine wave shock• Peak acceleration: 30 Grms• Shock duration: 11 ms• Operation mode: working with service connected• Test duration: 6 axial directions. 3 shocks for each axial direction.	JESD-B104-C	3 pcs/group	Visual inspection: ok Function test: ok RF specification: ok

Item		Test Condition	Standard	Sample size	Results
	Drop test	<ul style="list-style-type: none"> 0.8 m in height. Drop the module on the marble terrace with one surface facing downwards. Six surfaces should be tested. Operation mode: no power, no package 	IEC60068-2-32	3 pcs/group	Visual inspection: ok Function test: ok RF specification: ok
Life	High temperature operating life	<ul style="list-style-type: none"> Temperature: 70°C Operation mode: working with service connected Test duration: 168 h, 336 h, 500 h for inspection point 	JESD22-A108-B	50 pcs/group	Visual inspection: ok Function test: ok RF specification: ok
	High temperature & high humidity	<ul style="list-style-type: none"> High temperature: 85°C Humidity: 85% Operation mode: powered on and no working Test duration: 168 h, 336 h, 500 h for inspection point 	JESD22-A110-B	50 pcs/group	Visual inspection: ok Function test: ok RF specification: ok Cross section: ok
	Temperature cycle	<ul style="list-style-type: none"> High temperature: 85°C Low temperature: -40°C Temperature change slope: 6°C/min Operation mode: no power Test duration: 168 h, 336 h, 500 h for inspection point 	JESD22-A104-C	50 pcs/group	Visual inspection: ok Function test: ok RF specification: ok Cross section: ok
ESD	HBM (Human Body Model)	<ul style="list-style-type: none"> 2 kV (Class 1B) Operation mode: no power 	JESD22-A114-D	3 pcs/group	Visual inspection: ok Function test: ok RF specification: ok

- The EPA must use the ESD two-circuit wrist strap, and the wrist strap must be connected to the dedicated jack. The crocodile clip must not be connected to the ground.
- The ESD sensitive components, the processing equipment, test equipment, tools, and devices must be connected to the ground properly. The indexes are as follows:
 - Hard ground resistance $< 4 \Omega$
 - $1 \times 10^5 \Omega \leq$ Soft ground resistance $< 1 \times 10^9 \Omega$
 - $1 \times 10^5 \Omega \leq$ ICT fixture soft ground resistance $< 1 \times 10^{11} \Omega$
 - The electronic screwdriver and electronic soldering iron can be easily oxidized. Their ground resistance must be less than 20Ω .
- The parts of the equipment, devices, and tools that touch the ESD sensitive components and moving parts that are close to the ESD sensitive components must be made of ESD materials and have sound ground connection. The parts that are not made of ESD materials must be handled with ESD treatment, such as painting the ESD coating or ionization treatment (check that the friction voltage is less than 100 V).
- Key parts in the production equipment (parts that touch the ESD sensitive components or parts that are within 30 cm away from the ESD sensitive components), including the conveyor belt, conveyor chain, guide wheel, and SMT nozzle, must all be made of ESD materials and be connected to the ground properly (check that the friction voltage is less than 100 V).
- Engineers that touch IC chips, boards, modules, and other ESD sensitive components and assemblies must wear ESD wrist straps, ESD gloves, or ESD finger cots properly. Engineers that sit when handling the components must all wear ESD wrist straps.
- Noticeable ESD warning signs must be attached to the packages and placement areas of ESD sensitive components and assemblies.
- Boards and IC chips must not be stacked randomly or be placed with other ESD components.
- Effective shielding measures must be taken on the ESD sensitive materials that are transported or stored outside the EPA.



NOTE

HUAWEI MU709 module does not include any protection against overvoltage.

6 Mechanical Specifications

6.1 About This Chapter

This chapter mainly describes mechanical specifications of MU709 module, including:

- Dimensions and Interfaces
- Dimensions of the Mini PCI Express Connector
- Packaging
- Specification Selection for Fasteners
- Antenna Plug
- Thermal Design Guide

6.2 Dimensions and Interfaces

The dimensions (L × W × H) of the MU709 module is 51 mm × 30.4 mm × 3.27 mm. Figure 6-1 shows the dimensions of MU709 module in detail.

Figure 6-1 Dimensions of the MU709 module (Unit: mm)

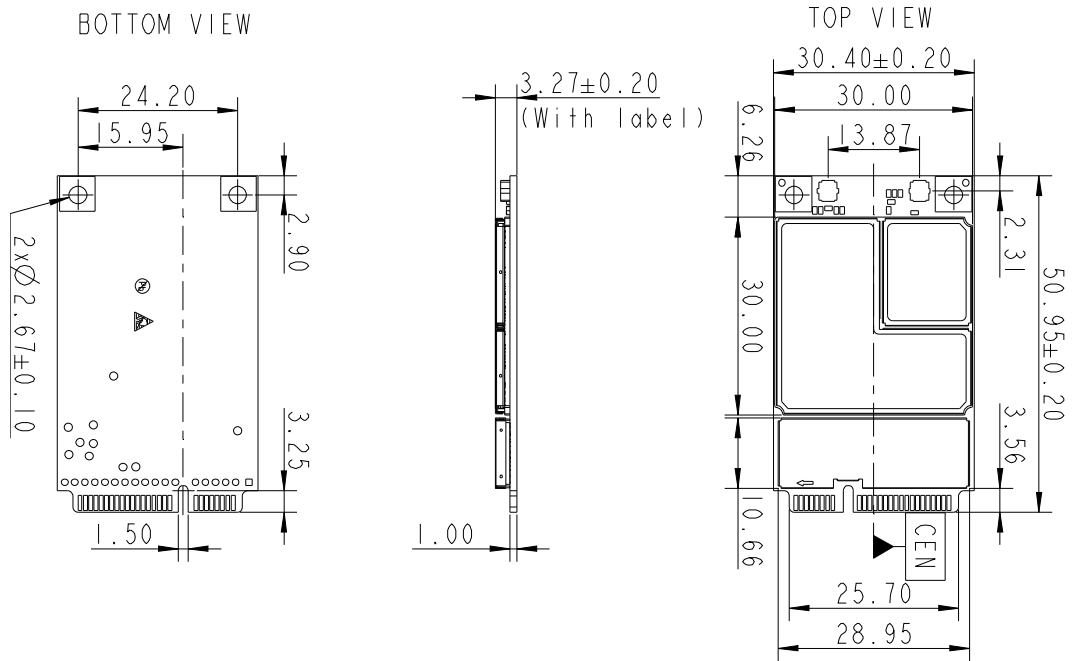

6.3 Dimensions of the Mini PCI Express Connector

The Mini PCIe Adapter adopts a standard Mini PCI Express connector that has 52 pins and complies with the [PCI Express Mini Card Electromechanical Specification Revision 2.0](#).

Figure 6-2 shows a 52-pin Mini PCI Express connector (take the Molex 67910002 as an example).

Figure 6-2 Dimensions of the Mini PCI Express connector (Unit: mm)

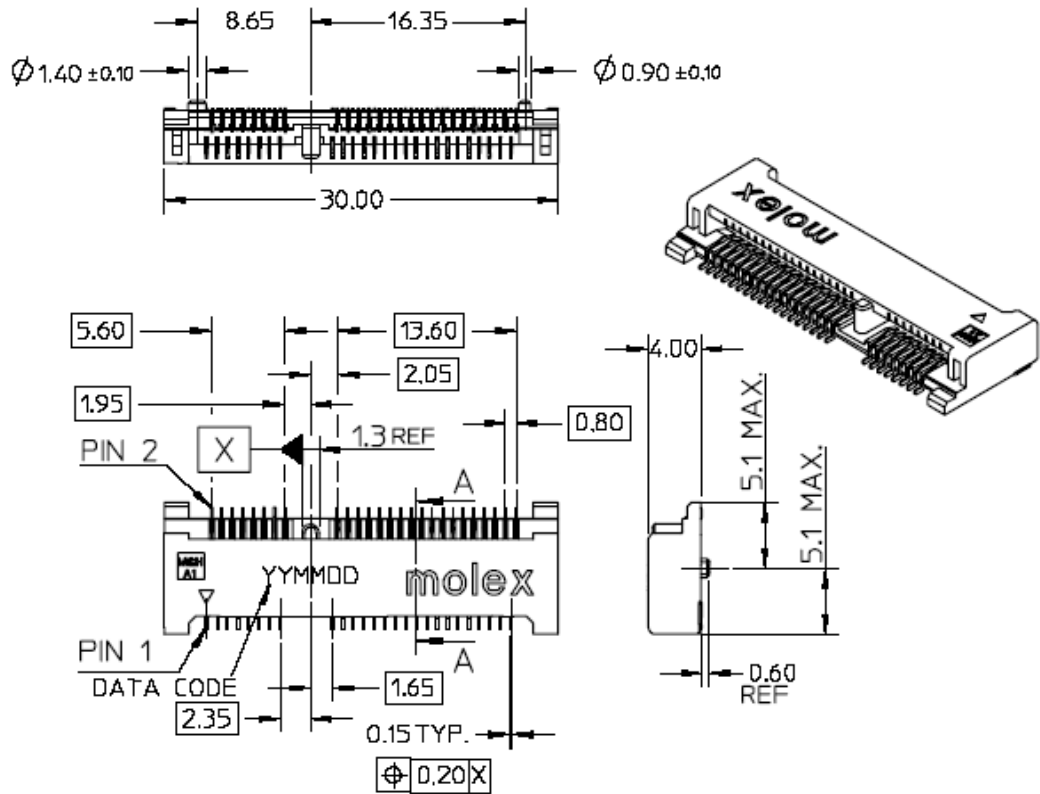

6.4 Packaging

HUAWEI Mini PCIe module uses anti-vibration foam and ESD bag into cartons.

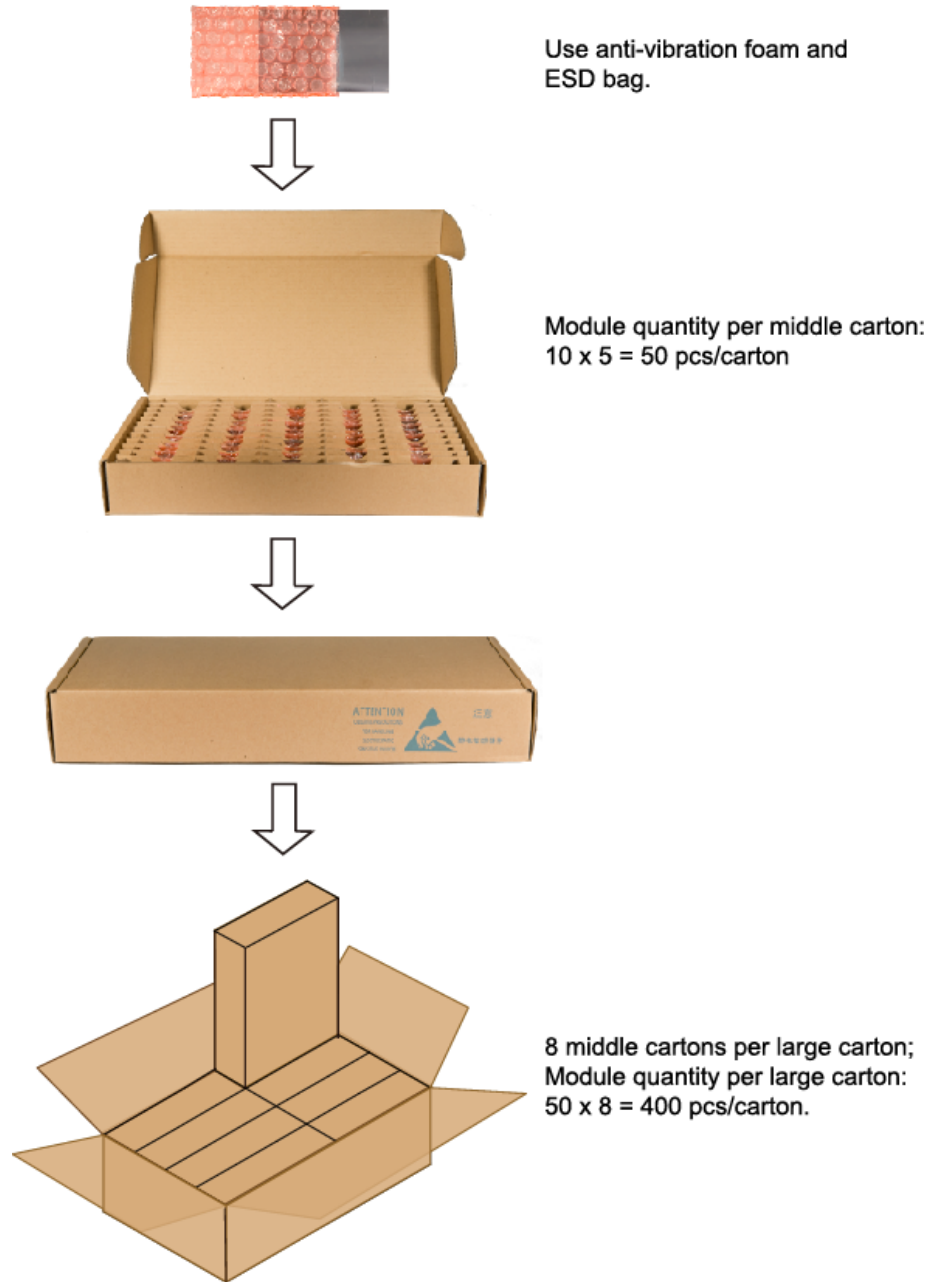

6.5 Specification Selection for Fasteners

6.5.1 Installing the Mini PCIe Adapter on the Main Board

To install the Mini PCIe Adapter on the main board, do the following:

Step 1 Insert the Mini PCIe Adapter into the Mini PCI Express connector on the main board.

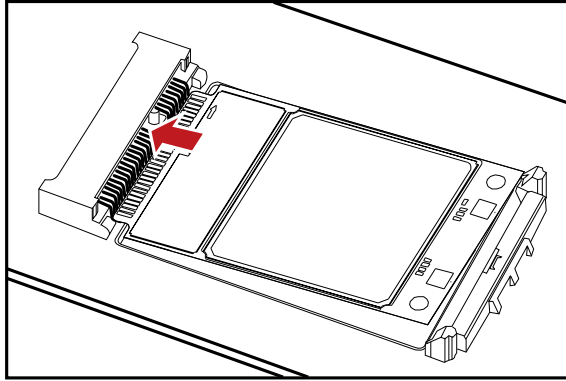

Step 2 Press downwards to fix the Mini PCIe Adapter in the module slot.

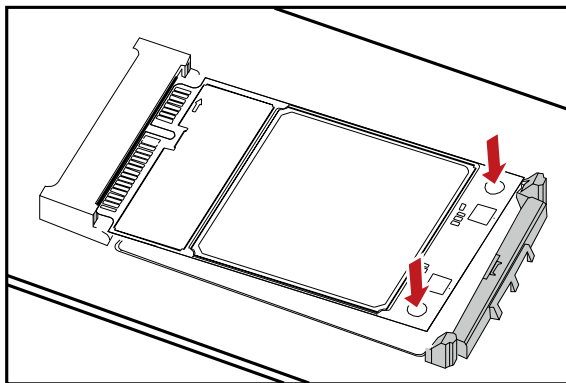

Step 3 Use a screwdriver to fix the Mini PCIe Adapter on the main board with two screws provided in the Mini PCIe Adapter packing box.

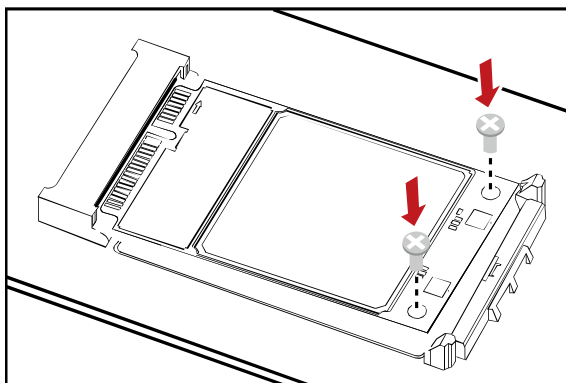

Step 4 Insert the connector of the main antenna into the MAIN antenna interface (M) of the Mini PCIe Adapter according to the indication on the label of the Mini PCIe Adapter. Insert the connector of the auxiliary antenna into the AUX antenna interface (A) of the Mini PCIe Adapter of the Mini PCIe Adapter in the same way.

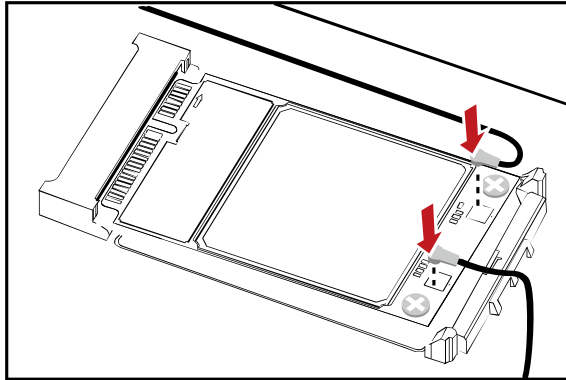

NOTE

- Insert the antenna connectors vertically into the antenna interfaces of the Mini PCIe Adapter.
- Do not press or squeeze the antenna cable or damage the connectors. Otherwise, the wireless performance of the Mini PCIe Adapter may be reduced or the Mini PCIe Adapter cannot work normally.
- Ensure that the antenna cables are routed through the channel in the frame of the PC and do not lay the cables across the raised edges of the frame.
- The module could not be installed or removed when the host is powered on. Otherwise, it may result in permanent damage to the module.

6.5.2 Removing the Mini PCIe Adapter from the Main Board

Step 1 Disconnect the antenna cables from the Mini PCIe Adapter. You can lift the connectors using a small screwdriver.

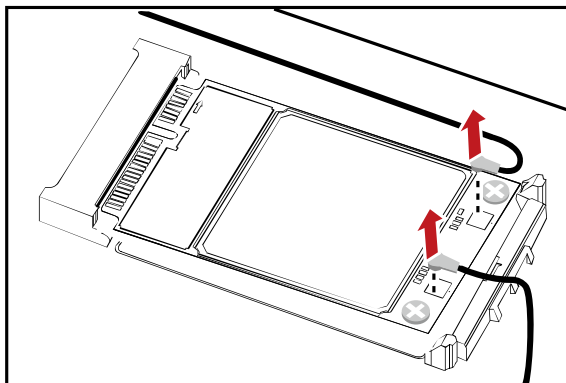

Step 2 Remove the two screws with the screwdriver.

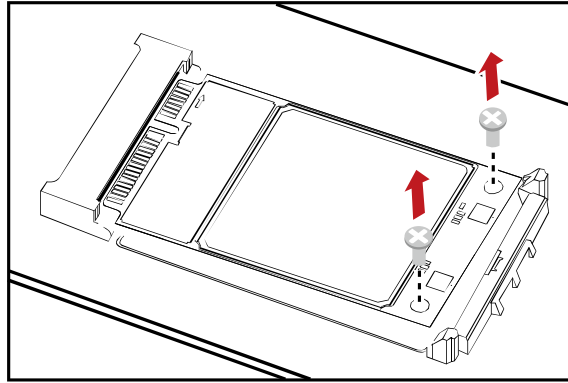

Step 3 Slide backwards the two clips to release the Mini PCIe Adapter from the slot. Then, lift up the Mini PCIe Adapter.

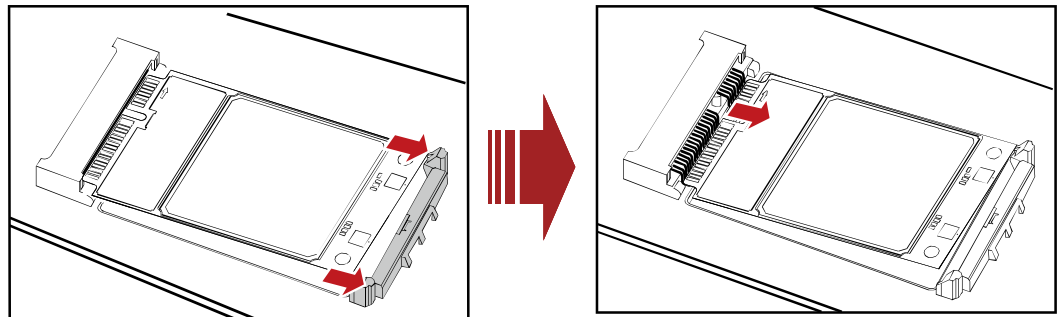

6.6 Antenna Plug

Figure 6-3 Mating the plug

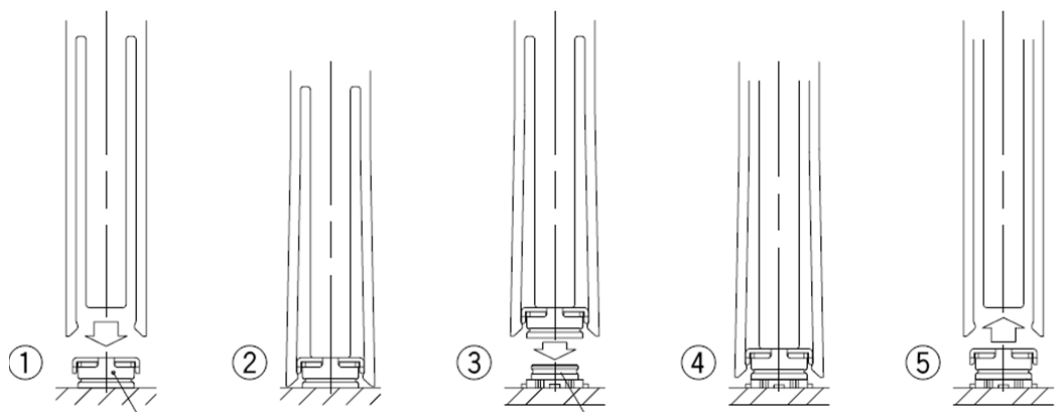

1. Align the mating tool or the mating end of the tool over the plug end of the cable assembly.
2. Firmly place the tool over the plug until it is secured in the tool.

3. Place the plug cable assembly (held in the tool) over the corresponding receptacle.
4. Assure that the plug and receptacle are aligned press-down perpendicular to the mounting surface until both connectors are fully mated.
5. Remove the mating tool by pulling it up carefully.

Figure 6-4 Unmating the plug

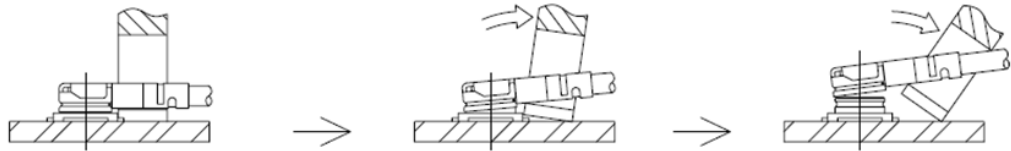

NOTE

- The extraction tool is recommended.
- Any attempt of unmating by pulling on the cable may result in damage and influence the mechanical/electrical performance.

It is recommended not to apply any pull forces after the bending of the cable, as described in Figure 6-5 .

Figure 6-5 Do not apply any pull forces after the bending of the cable

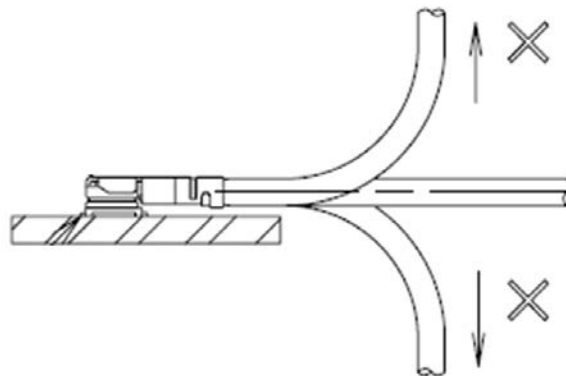

6.7 Thermal Design Guide

When using in the network, the MU709 module (Mini PCIe) have high power consumption. To improve the module reliability and stability, focus on the thermal design of the device to speed up heat dissipation.

Take the following heat dissipation measures:

- Do not hollow out the customer PCB.
- Attach the thermal conductive material between the Mini PCIe and the customer PCB. The recommended thermal conductivity of the thermal conductive material is 1.0 W/m-k or higher (recommended manufacturers: Laird and Bergquist). The

dimensions (W x D) of the thermal conductive material are 38 mm x 28 mm (1.50 in. x 1.10 in.), and its height depends on the height of the Mini PCIe connector you use and the method for installing the Mini PCIe. When deciding the height of the thermal conductive material, you are advised to obey the following rule: After the Mini PCIe is fastened to the customer PCB, the compression amount of the thermal conductive material accounts for 15% to 30% of the thermal conductive material size. For example, if you use a connector shown in the following figure and install the Mini PCIe like this, the recommended height of the thermal conductive material is 1.8 mm (0.07 in.).

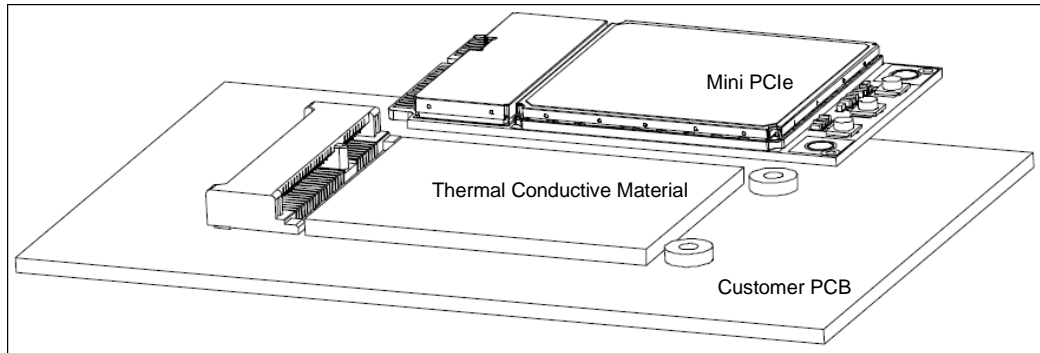

- On the customer PCB, reserve two metal screw holes, which are connected to the PCB ground plane. When installing the Mini PCIe, use two metal screws to fasten the Mini PCIe to the customer PCB. See the following figure.



03-9243358 :פקס ▪ 03-9243352 :לוח ▪ 7042 פ"ת ▪ ת"ד 14, ת.ת. 7042 פ"ת ▪
www.hypertech.co.il ▪ sales@hypertech.co.il

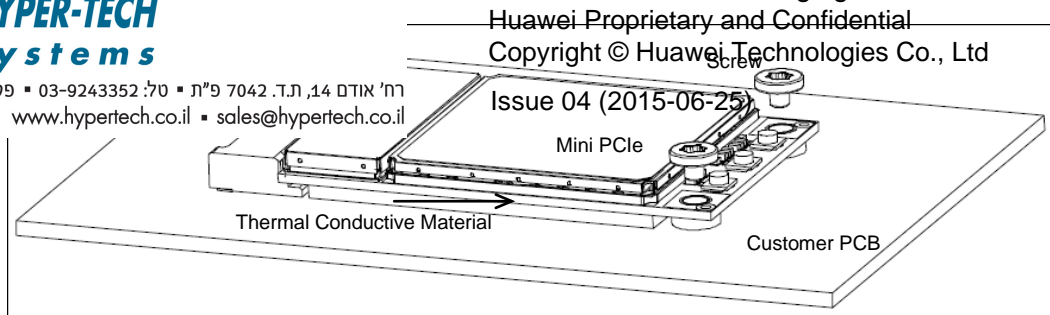

- Ensure that the air flow around the Mini PCIe is sufficient.
- Try not to place any component in the Mini PCIe's projection region on the customer PCB. Do not place components with 1.5 W or higher power consumption or heat sensitive components (such as crystals) near the Mini PCIe.
- Use a large customer PCB. The recommended size (W x D) is 70 mm x 70 mm (2.76 in. x 2.76 in.).
- If the thermal conductive material is attached between the Mini PCIe and the customer PCB, then the heat dissipation performance will be better for multilayer PCB.
- Apply copper to the region for attaching the thermal conductive material to the customer PCB. Try to use the continuous ground plane design on the customer PCB, and each ground plane must be connected through holes. Therefore, reserve holes as many as possible.



NOTE

If you do not take the preceding heat dissipation measures, the overheat protection mechanism is triggered due to overheated Mini PCIe and the network connection is terminated when the Mini PCIe keeps working in enclosed space with a 70°C temperature and a big current for a period of time. You can resume the network connection only after the temperature drops.

7 Certifications

7.1 About This Chapter

This chapter gives a general description of certifications of MU709 module.

7.2 Certifications

**NOTE**

Table 7-1 shows certifications of the MU709 module have been implemented. For more demands, please contact us for more details about this information.

Table 7-1 Product Certifications

Certification	Model name	
	MU709s-2	MU709s-6
CE	√	√
CCC	√	-
FCC	-	√
Anetel	-	√
RoHS	√	√
WEEE	√	√
NAL	√	-
SRRC	√	-
REACH	√	√
RCM	-	√
NCC	√	√

8 Safety Information

Read the safety information carefully to ensure the correct and safe use of your wireless device. Applicable safety information must be observed.

8.1 Interference

Power off your wireless device if using the device is prohibited. Do not use the wireless device when it causes danger or interference with electric devices.

8.2 Medical Device

- Power off your wireless device and follow the rules and regulations set forth by the hospitals and health care facilities.
- Some wireless devices may affect the performance of the hearing aids. For any such problems, consult your service provider.
- Pacemaker manufacturers recommend that a minimum distance of 15 cm be maintained between the wireless device and a pacemaker to prevent potential interference with the pacemaker. If you are using an electronic medical device, consult the doctor or device manufacturer to confirm whether the radio wave affects the operation of this device.

8.3 Area with Inflammables and Explosives

To prevent explosions and fires in areas that are stored with inflammable and explosive devices, power off your wireless device and observe the rules. Areas stored with inflammables and explosives include but are not limited to the following:

- Gas station
- Fuel depot (such as the bunk below the deck of a ship)
- Container/Vehicle for storing or transporting fuels or chemical products
- Area where the air contains chemical substances and particles (such as granule, dust, or metal powder)
- Area indicated with the "Explosives" sign

- Area indicated with the "Power off bi-direction wireless equipment" sign
- Area where you are generally suggested to stop the engine of a vehicle

8.4 Traffic Security

- Observe local laws and regulations while using the wireless device. To prevent accidents, do not use your wireless device while driving.
- RF signals may affect electronic systems of motor vehicles. For more information, consult the vehicle manufacturer.
- In a motor vehicle, do not place the wireless device over the air bag or in the air bag deployment area. Otherwise, the wireless device may hurt you owing to the strong force when the air bag inflates.

8.5 Airline Security

Observe the rules and regulations of airline companies. When boarding or approaching a plane, power off your wireless device. Otherwise, the radio signal of the wireless device may interfere with the plane control signals.

8.6 Safety of Children

Do not allow children to use the wireless device without guidance. Small and sharp components of the wireless device may cause danger to children or cause suffocation if children swallow the components.

8.7 Environment Protection

Observe the local regulations regarding the disposal of your packaging materials, used wireless device and accessories, and promote their recycling.

8.8 WEEE Approval

The wireless device is in compliance with the essential requirements and other relevant provisions of the Waste Electrical and Electronic Equipment Directive 2012/19/EU (WEEE Directive).

8.9 RoHS Approval

The wireless device is in compliance with the restriction of the use of certain hazardous substances in electrical and electronic equipment Directive 2011/65/EU (RoHS Directive).

8.10 Laws and Regulations Observance

Observe laws and regulations when using your wireless device. Respect the privacy and legal rights of the others.

8.11 Care and Maintenance

It is normal that your wireless device gets hot when you use or charge it. Before you clean or maintain the wireless device, stop all applications and power off the wireless device.

- Use your wireless device and accessories with care and in clean environment. Keep the wireless device from a fire or a lit cigarette.
- Protect your wireless device and accessories from water and vapour and keep them dry.
- Do not drop, throw or bend your wireless device.
- Clean your wireless device with a piece of damp and soft antistatic cloth. Do not use any chemical agents (such as alcohol and benzene), chemical detergent, or powder to clean it.
- Do not leave your wireless device and accessories in a place with a considerably low or high temperature.
- Use only accessories of the wireless device approved by the manufacture. Contact the authorized service center for any abnormality of the wireless device or accessories.
- Do not dismantle the wireless device or accessories. Otherwise, the wireless device and accessories are not covered by the warranty.
- The device should be installed and operated with a minimum distance of 20 cm between the radiator and your body.

8.12 Emergency Call

This wireless device functions through receiving and transmitting radio signals. Therefore, the connection cannot be guaranteed in all conditions. In an emergency, you should not rely solely on the wireless device for essential communications.

8.13 Regulatory Information

The following approvals and notices apply in specific regions as noted.

8.13.1 CE Approval (European Union)

The wireless device is approved to be used in the member states of the EU. The wireless device is in compliance with the essential requirements and other relevant provisions of the Radio and Telecommunications Terminal Equipment Directive 1999/5/EC (R&TTE Directive).



8.13.2 FCC Statement

Federal Communications Commission Notice (United States): Before a wireless device model is available for sale to the public, it must be tested and certified to the FCC that it does not exceed the limit established by the government-adopted requirement for safe exposure.

This device complies with Part 15 of the FCC Rules. Operation is subject to the following two conditions: (1) this device may not cause harmful interference, and (2) this device must accept any interference received, including interference that may cause undesired operation.

Warning: Changes or modifications made to this equipment not expressly approved by HUAWEI may void the FCC authorization to operate this equipment.

10 Appendix B Acronyms and Abbreviations

Acronym or Abbreviation	Expansion
3GPP	Third Generation Partnership Project
AUX	Auxiliary
CCC	China Compulsory Certification
CE	European Conformity
DC	Direct Current
EDGE	Enhanced Data Rate for GSM Evolution
EMC	Electromagnetic Compatibility
ESD	Electrostatic Discharge
EU	European Union
FCC	Federal Communications Commission
GPIO	General-purpose I/O
GPRS	General Packet Radio Service
GSM	Global System for Mobile Communication
HSDPA	High-Speed Downlink Packet Access
HSPA	High Speed Packet Access
HSUPA	High Speed Up-link Packet Access
ISO	International Standards Organization
LDO	Low-Dropout
LED	Light-Emitting Diode
OC	Open Collector

Acronym or Abbreviation	Expansion
PCB	Printed Circuit Board
RF	Radio Frequency
RoHS	Restriction of the Use of Certain Hazardous Substances
TVS	Transient Voltage Suppressor
UMTS	Universal Mobile Telecommunications System
USB	Universal Serial Bus
USIM	Universal Subscriber Identity Module
VSWR	Voltage Standing Wave Ratio
WCDMA	Wideband Code Division Multiple Access
WEEE	Waste Electrical and Electronic Equipment