



HUAWEI ME209u-526 LTE Mini PCIe Module

Hardware Guide

Issue 01

Date 2015-03-17



ח'א אודם 14, ת.ד. 7042 פ"ת • סל: 03-9243352 • פקס: 03-9243358
www.hypertech.co.il • sales@hypertech.co.il

Copyright © Huawei Technologies Co., Ltd. 2015. All rights reserved.

No part of this manual may be reproduced or transmitted in any form or by any means without prior written consent of Huawei Technologies Co., Ltd. and its affiliates ("Huawei").

The product described in this manual may include copyrighted software of Huawei and possible licensors. Customers shall not in any manner reproduce, distribute, modify, decompile, disassemble, decrypt, extract, reverse engineer, lease, assign, or sublicense the said software, unless such restrictions are prohibited by applicable laws or such actions are approved by respective copyright holders.

Trademarks and Permissions



HUAWEI, HUAWEI, and  are trademarks or registered trademarks of Huawei Technologies Co., Ltd.

LTE is a trade mark of ETSI.

Other trademarks, product, service and company names mentioned may be the property of their respective owners.

Notice

Some features of the product and its accessories described herein rely on the software installed, capacities and settings of local network, and therefore may not be activated or may be limited by local network operators or network service providers.

Thus, the descriptions herein may not exactly match the product or its accessories which you purchase.

Huawei reserves the right to change or modify any information or specifications contained in this manual without prior notice and without any liability.

DISCLAIMER

ALL CONTENTS OF THIS MANUAL ARE PROVIDED "AS IS". EXCEPT AS REQUIRED BY APPLICABLE LAWS, NO WARRANTIES OF ANY KIND, EITHER EXPRESS OR IMPLIED, INCLUDING BUT NOT LIMITED TO, THE IMPLIED WARRANTIES OF MERCHANTABILITY AND FITNESS FOR A PARTICULAR PURPOSE, ARE MADE IN RELATION TO THE ACCURACY, RELIABILITY OR CONTENTS OF THIS MANUAL.

TO THE MAXIMUM EXTENT PERMITTED BY APPLICABLE LAW, IN NO EVENT SHALL HUAWEI BE LIABLE FOR ANY SPECIAL, INCIDENTAL, INDIRECT, OR CONSEQUENTIAL DAMAGES, OR LOSS OF PROFITS, BUSINESS, REVENUE, DATA, GOODWILL SAVINGS OR ANTICIPATED SAVINGS REGARDLESS OF WHETHER SUCH LOSSES ARE FORSEEABLE OR NOT.

THE MAXIMUM LIABILITY (THIS LIMITATION SHALL NOT APPLY TO LIABILITY FOR PERSONAL INJURY TO THE EXTENT APPLICABLE LAW PROHIBITS SUCH A LIMITATION) OF HUAWEI ARISING FROM THE USE OF THE PRODUCT DESCRIBED IN THIS MANUAL SHALL BE LIMITED TO THE AMOUNT PAID BY CUSTOMERS FOR THE PURCHASE OF THIS PRODUCT.

Import and Export Regulations

Customers shall comply with all applicable export or import laws and regulations and be responsible to obtain all necessary governmental permits and licenses in order to export, re-export or import the product mentioned in this manual including the software and technical data therein.

Privacy Policy

To better understand how we protect your personal information, please see the privacy policy at <http://consumer.huawei.com/privacy-policy>.





About This Document

Revision History

Document Version	Date	Chapter	Descriptions
01	2015-03-17		Creation



Contents

1 Introduction.....	7
2 Overall Description	8
2.1 About This Chapter.....	8
2.2 Function Overview.....	8
2.3 Circuit Block Diagram.....	9
3 Description of the Application Interfaces.....	11
3.1 About This Chapter.....	11
3.2 Mini PCIe Interface.....	11
3.3 Power Interface	16
3.3.1 Power Sources and Grounds	16
3.3.2 Power Supply Time Sequence	16
3.4 Signal Control Interface.....	17
3.4.1 Overview.....	17
3.4.2 WAKE# Signal	18
3.4.3 RESIN_N Signal	18
3.4.4 W_DISABLE# Signal	20
3.4.5 LED_WWAN# Signal	20
3.5 USB Interface.....	21
3.6 USIM Card Interface	21
3.6.1 Overview.....	21
3.6.2 Circuit Recommended for the USIM Card Interface.....	22
3.7 Audio Interface	23
3.8 NC Pins	25
4 RF Specifications.....	26
4.1 About This Chapter.....	26
4.2 Operating Frequencies.....	26
4.3 Conducted RF Measurement	26
4.3.1 Test Environment.....	26
4.3.2 Test Standards	27
4.4 Conducted Rx Sensitivity and Tx Power	27
4.4.1 Conducted Receive Sensitivity.....	27
4.4.2 Conducted Transmit Power	27



4.5 Antenna Design Requirements	28
4.5.1 Antenna Design Indicators.....	28
4.5.2 Interference	30
4.5.3 Antenna Requirements	30
5 Electrical and Reliability Features	32
5.1 About This Chapter.....	32
5.2 Absolute Ratings	32
5.3 Operating and Storage Temperatures	32
5.4 Power Supply Features	33
5.4.1 Input Power Supply	33
5.4.2 Power Consumption	34
5.5 Reliability Features.....	35
5.6 EMC and ESD Features.....	38
6 Mechanical Specifications.....	40
6.1 About This Chapter.....	40
6.2 Dimensions and Interfaces.....	40
6.3 Dimensions of the Mini PCI Express Connector	41
6.4 Packaging.....	42
6.5 Specification Selection for Fasteners	43
6.5.1 Installing the Mini PCIe Adapter on the Main Board	43
6.5.2 Removing the Mini PCIe Adapter from the Main Board	45
6.6 Antenna Plug	46
6.7 Thermal Design Guide	47
7 Certifications.....	50
7.1 About This Chapter.....	50
7.2 Certifications.....	50
8 Safety Information.....	51
8.1 Interference	51
8.2 Medical Device	51
8.3 Area with Inflammables and Explosives.....	51
8.4 Traffic Security.....	52
8.5 Airline Security.....	52
8.6 Safety of Children.....	52
8.7 Environment Protection	52
8.8 WEEE Approval.....	52
8.9 RoHS Approval.....	52
8.10 Laws and Regulations Observance	53
8.11 Care and Maintenance	53
8.12 Emergency Call	53
8.13 Regulatory Information.....	53



8.13.1 FCC Statement	53
9 Appendix A Circuit of Typical Interface	55
10 Appendix B Acronyms and Abbreviations	56



1 Introduction

This document describes the hardware application interfaces and air interfaces provided by HUAWEI ME209u-526 Mini PCIe module (hereinafter referred to as the ME209u-526 Mini PCIe module).

This document helps hardware engineer to understand the interface specifications, electrical features and related product information of the ME209u-526 Mini PCIe module.

2 Overall Description

2.1 About This Chapter

This chapter gives a general description of the ME209u-526 Mini PCIe module and provides:

- Function Overview
- Circuit Block Diagram

2.2 Function Overview

Table 2-1 Features

Feature	Description
Physical Dimensions	<ul style="list-style-type: none">• Dimensions (L × W × H): 51 mm × 30.4 mm × 3.4 mm• Weight: about 12 g
Operating Bands	LTE: FDD Band 4, Band 13, all bands with diversity
Operating Temperature	Normal operating temperature: –30°C to +70°C Extended operating temperature ^[1] : –40°C to +75°C
Storage Temperature	–40°C to +85°C
Power Voltage	DC 3.0 V–3.6 V (typical value is 3.3 V)
AT Commands	See the HUAWEI ME209u-526 LTE Module AT Command Interface Specification
Application Interface (52-pin Mini PCIe interface)	Standard USIM (Class B and Class C) interface
	Audio interface: PCM interface ^[2]
	USB 2.0 (High Speed)

Feature	Description
	RESIN_N: Reset module
	WAKE#: Wakeup out signal
	W_DISABLE# signal ^[2]
	LED_WWAN#: Active-low LED signal indicating the state of the module
Antenna Connector	WWAN MAIN antenna connector x1 WWAN AUX antenna connector x1
Data Services	LTE FDD: DL 100 Mbit/s; UL 50 Mbit/s @20M BW cat3



NOTE

- [1]: When the ME209u-526 Mini PCIe module works in the range of -40°C to -30°C or $+70^{\circ}\text{C}$ to $+75^{\circ}\text{C}$, **NOT** all its RF performances comply with 3GPP specifications. The thermal design must be implemented according to the chapter 6.7. If not, the overheat protection mechanism will be triggered due to overheated Mini PCIe and the network connection will be terminated.
- [2]: The firmware does not support these features yet.

2.3 Circuit Block Diagram

Figure 2-1 shows the circuit block diagram of the ME209u-526 Mini PCIe Adapter. The major functional unit of the Mini PCIe Adapter contains the following parts:

- LGA module
- Control signals
- Antenna connectors

Figure 2-1 Circuit block diagram of the ME209u-526 Mini PCIe module

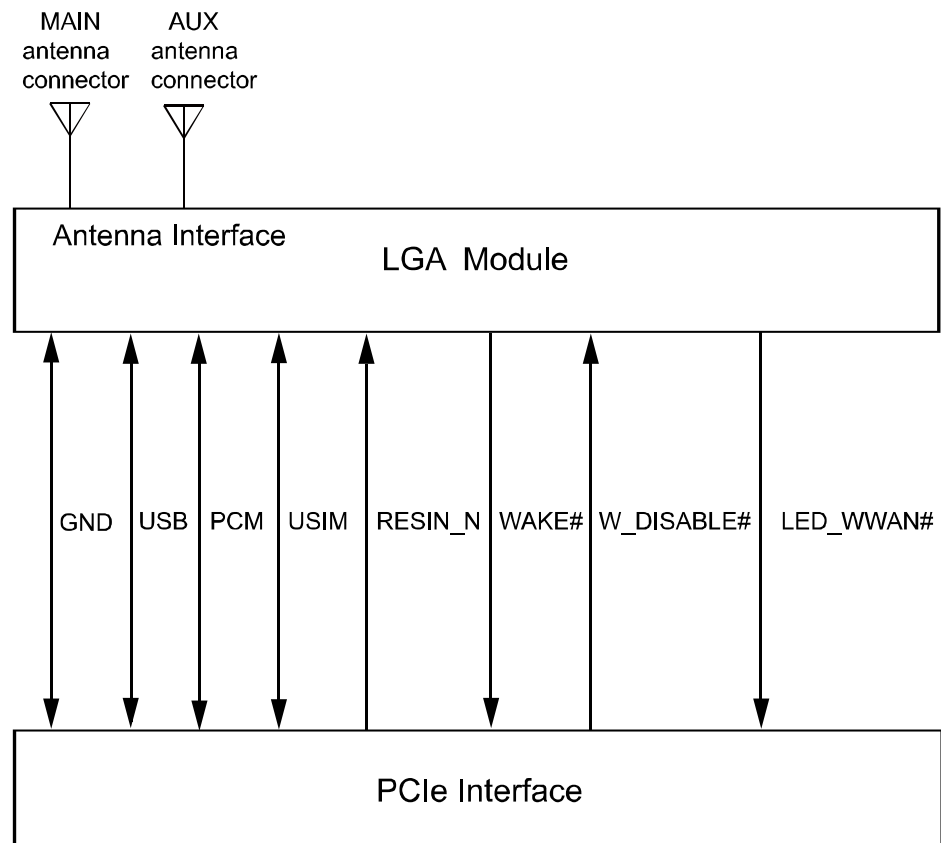

3 Description of the Application Interfaces

3.1 About This Chapter

This chapter mainly describes the external application interfaces of the ME209u-526 Mini PCIe module, including:

- Mini PCIe Interface
- Power Interface
- Signal Control Interface
- USB Interface
- USIM Card Interface
- Audio Interface
- NC Pins

3.2 Mini PCIe Interface

The ME209u-526 Mini PCIe module uses a Mini PCIe interface as its external interface. For details about the module and dimensions, see 6.2 Dimensions and Interfaces.

Figure 3-1 shows the appearance of pins on the interface of the Mini PCIe Adapter.

Figure 3-1 Appearance of Mini PCIe interface

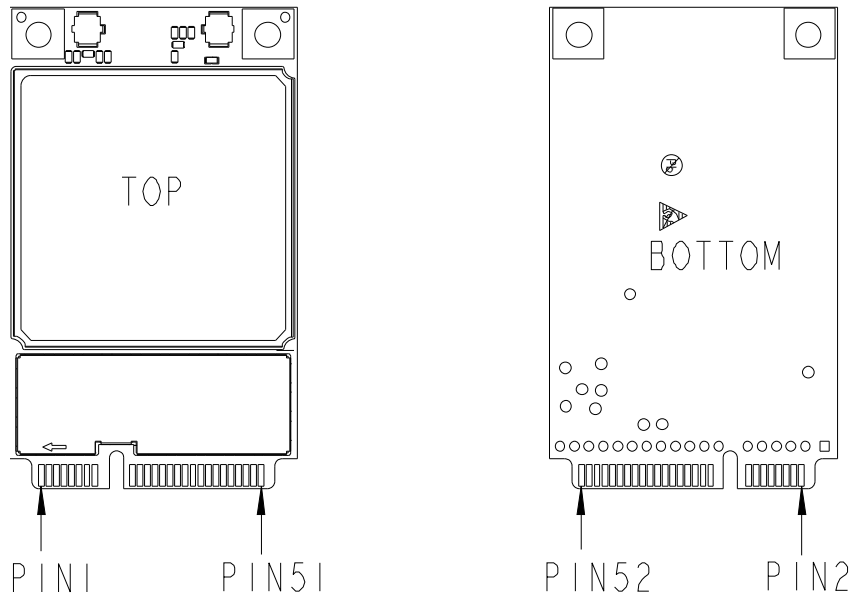

Table 3-1 shows the pin definitions of the Mini PCIe interface.

Table 3-1 Pin definitions of the Mini PCIe interface

Pin No.	Pin Name		Pad Type	Description	Parameter	Min. (V)	Typ. (V)	Max. (V)	Comment
	Mini PCI Express Standard Description	HUAWEI Pin Description							
1	WAKE#	WAKE#	O	Open collector active low signal. This signal is used to wake up the host.	V _{OH}	1.35	1.8	1.8	-
					V _{OL}	0	-	0.45	-
2	3.3Vaux	VCC_3V3	PI	3.3 V DC supply input	-	3.0	3.3	3.6	-
3	COEX1	NC	-	Not connected	-	-	-	-	-
4	GND	GND	-	Ground	-	-	-	-	-
5	COEX2	NC	-	Not connected	-	-	-	-	-
6	1.5 V	NC	-	Not connected	-	-	-	-	-
7	CLKREQ#	NC	-	Not connected	-	-	-	-	-
8	UIM_PWR	USIM_PWR	PO	Power source for the external	-	-0.3	1.8	1.98	USIM_VCC=1.8 V

Pin No.	Pin Name		Pad Type	Description	Parameter	Min. (V)	Typ. (V)	Max. (V)	Comment
	Mini PCI Express Standard Description	HUAWEI Pin Description							
				USIM card	-	-0.3	2.85	3.3	USIM_VCC=3.0 V
9	GND	GND	-	Ground	-	-	-	-	-
10	UIM_DATA	USIM_DATA	I/O	External USIM data signal	V _{IH}	0.65 x USIM_VCC	-	3.3	USIM_VCC=1.8 V or 3.0 V
					V _{IL}	0	-	0.25 x USIM_VCC	
					V _{OH}	0.7 x USIM_VCC	-	3.3	
					V _{OL}	0	-	0.2 x USIM_VCC	
11	REFCLK-	NC	-	Not connected	-	-	-	-	-
12	UIM_CLK	USIM_CLK	O	External USIM clock signal	V _{OH}	0.7 x USIM_VCC	-	3.3	USIM_VCC=1.8 V or 3.0 V
					V _{OL}	0	-	0.2 x USIM_VCC	
13	REFCLK+	NC	-	Not connected	-	-	-	-	-
14	UIM_RESET	USIM_RESET	O	External USIM reset signal	V _{OH}	0.7 x USIM_VCC	-	3.3	USIM_VCC=1.8 V or 3.0 V
					V _{OL}	0	-	0.2 x USIM_VCC	
15	GND	GND	-	Ground	-	-	-	-	-
16	UIM_Vpp	NC	-	Not connected	-	-	-	-	-
17	Reserved	NC	-	Not connected	-	-	-	-	-
18	GND	GND	-	Ground	-	-	-	-	-
19	Reserved	NC	-	Not connected	-	-	-	-	-
20	W_DISABLE#	W_DISABLE#	I	The	V _{IL}	-0.3	0	0.3	-



Pin No.	Pin Name		Pad Type	Description	Parameter	Min. (V)	Typ. (V)	Max. (V)	Comment
	Mini PCI Express Standard Description	HUAWEI Pin Description							
				W_DISABLE# signal is an active low signal that when asserted (driven low) by the system shall disable radio operation. ^[1]	V _{IH}	1.17	1.8	2.1	-
21	GND	GND	-	Ground	-	-	-	-	-
22	PERST#	RESIN_N	I	Reset module Active-low	V _{IL}	-0.3	0	0.3	-
					V _{IH}	1.17	1.8	2.1	-
23	PERn0	NC	-	Not connected	-	-	-	-	-
24	3.3Vaux	VCC_3V3	PI	3.3 V DC supply input.	-	3.0	3.3	3.6	-
25	PERp0	NC	-	Not connected	-	-	-	-	-
26	GND	GND	-	Ground	-	-	-	-	-
27	GND	GND	-	Ground	-	-	-	-	-
28	1.5 V	NC	-	Not connected	-	-	-	-	-
29	GND	GND	-	Ground	-	-	-	-	-
30	SMB_CLK	NC	-	Not connected	-	-	-	-	-
31	PETn0	NC	-	Not connected	-	-	-	-	-
32	SMB_DATA	NC	-	Not connected	-	-	-	-	-
33	PETp0	NC	-	Not connected	-	-	-	-	-
34	GND	GND	-	Ground	-	-	-	-	-
35	GND	GND	-	Ground	-	-	-	-	-
36	USB_D-	USB_DM	I/O	USB signal D-	-	-	-	-	-
37	GND	GND	-	Ground	-	-	-	-	-
38	USB_D+	USB_DP	I/O	USB signal D+	-	-	-	-	-
39	3.3Vaux	VCC_3V3	PI	3.3 V DC supply input.	-	3.0	3.3	3.6	-
40	GND	GND	-	Ground	-	-	-	-	-

Pin No.	Pin Name		Pad Type	Description	Parameter	Min. (V)	Typ. (V)	Max. (V)	Comment
	Mini PCI Express Standard Description	HUAWEI Pin Description							
41	3.3Vaux	VCC_3V3	PI	3.3 V DC supply input.	-	3.0	3.3	3.6	-
42	LED_WWAN#	LED_WWAN#	O	Active-low LED signal indicating the state of the card.	V _{OL}	-0.3	0	0.45	-
					V _{OH}	1.35	1.8	2.1	-
43	GND	GND	-	Ground	-	-	-	-	-
44	LED_WLAN#	NC	-	Not connected	-	-	-	-	-
45	Reserved	PCM_CLK	O	PCM interface clock ^[1]	V _{OL}	-0.3	0	0.45	-
					V _{OH}	1.35	1.8	2.1	-
46	LED_WPAN#	NC	-	Not connected	-	-	-	-	-
47	Reserved	PCM_DOUT	O	PCM I/F data out ^[1]	V _{OL}	-0.3	0	0.45	-
					V _{OH}	1.35	1.8	2.1	-
48	1.5 V	NC	-	Not connected	-	-	-	-	-
49	Reserved	PCM_DIN	I	PCM I/F data in ^[1]	V _{IL}	-0.3	0	0.63	-
					V _{IH}	1.17	1.8	2.1	-
50	GND	GND	-	Ground	-	-	-	-	-
51	Reserved	PCM_SYNC	O	PCM interface sync ^[1]	V _{OL}	-0.3	0	0.45	-
					V _{OH}	1.35	1.8	2.1	-
52	3.3Vaux	VCC_3V3	PI	3.3 V DC supply input.	-	3.0	3.3	3.6	-



NOTE

- **P** indicates power pins; **I** indicates pins for digital signal input; **O** indicates pins for digital signal output; **PI** indicates power input pins; **PO** indicates power output pins.
- **V_{IL}** indicates Low-level Input voltage; **V_{IH}** indicates High-level Input voltage; **V_{OL}** indicates Low-level Output voltage; **V_{OH}** indicates High-level Output voltage.
- The **NC** (Not Connected) pins are floating and there are no signal connected to these pins. Therefore, these pins should not be used.
- [1] The firmware does not support these features yet.

3.3 Power Interface

3.3.1 Power Sources and Grounds

For the Mini PCIe Adapter, +3.3V_{aux} is the only voltage supply that is available. The input voltage is 3.3 V \pm 9%, as specified by *PCI Express Mini Card Electromechanical Specification Revision 1.2*.

Table 3-2 Power and ground specifications

Pin No.	Pin Name	Pad Type	Description	Min. (V)	Typ. (V)	Max. (V)
2, 24, 39, 41 and 52	VCC_3V3	PI	3.3 V DC supply input	3.0	3.3	3.6
4, 9, 15, 18, 21, 26, 27, 29, 34, 35, 37, 40, 43 and 50	GND	-	Ground	-	-	-



NOTE

To minimize the RF radiation through the power lines, it is suggested to add ceramic capacitors of 10 pF and 100 nF in the power lines beside the Mini PCIe connector on the host side.

3.3.2 Power Supply Time Sequence

Power on sequence

Do not toggle RESIN_N pin during the power on sequence. Pull-Down RESIN_N pin will extend time for module startup.

Figure 3-2 Power on time sequence

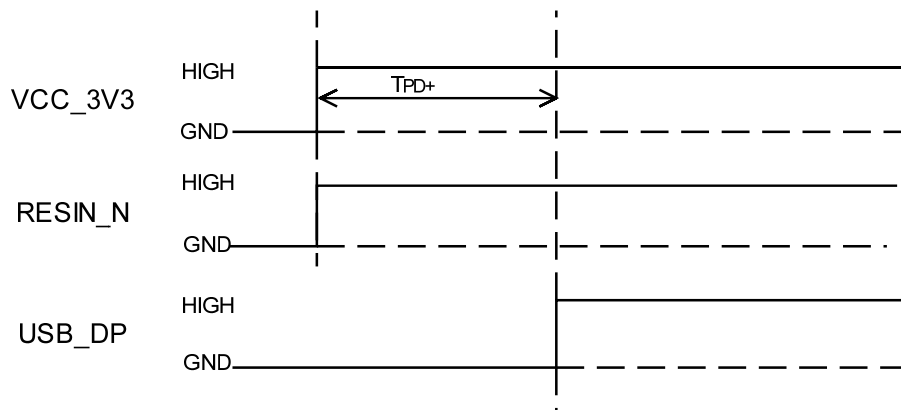

Parameter	Remarks	Time (Nominal value)	Unit
T _{PD+}	Power Valid to USB D+ high	12	s

Power off sequence

Cutting off VCC_3V3 powers off the module.

Figure 3-3 Power off time sequence

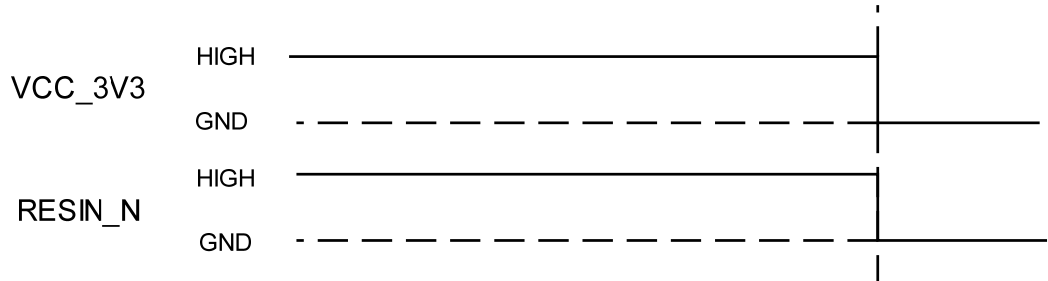

3.4 Signal Control Interface

3.4.1 Overview

The signal control part of the interface in the ME209u-526 Mini PCIe module consists of the following:

- WAKE# signal
- RESIN_N signal
- W_DISABLE# signal
- LED_WWAN# signal

Table 3-3 lists the pins on the signal control interface.

Table 3-3 Definitions of the pins on the signal control interface

Pin No.	Pin Name	Pad Type	Description	Parameter	Min. (V)	Typ. (V)	Max. (V)
1	WAKE#	O	Open collector active low signal. This signal is used to wake up the host.	V_{OH}	1.35	1.8	1.8
				V_{OL}	0	-	0.45
22	RESIN_N	I	Reset module Active-low	V_{IL}	-0.3	0	0.3
				V_{IH}	1.17	1.8	2.1
20	W_DISABLE#	I	The W_DISABLE# signal is an active low signal that when asserted (driven low) by the system shall disable radio operation.	V_{IL}	-0.3	0	0.3
				V_{IH}	1.17	1.8	2.1
42	LED_WWAN#	O	Active-low LED signal indicating the state of the card.	V_{OL}	-0.3	0	0.45
				V_{OH}	1.35	1.8	2.1

3.4.2 WAKE# Signal

WAKE# pin supports software control. This signal is used for module to wake up the host. It is designed as an OC gate, so it should be pulled up by the host and it is active-low.

When the module wakes up the host, the WAKE# pin will output low-level-voltage to wake the host.

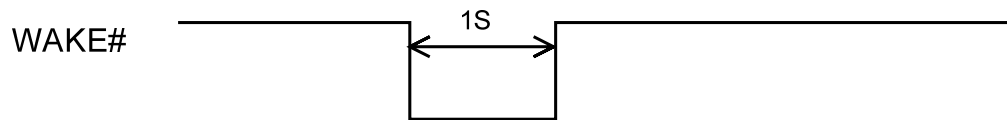
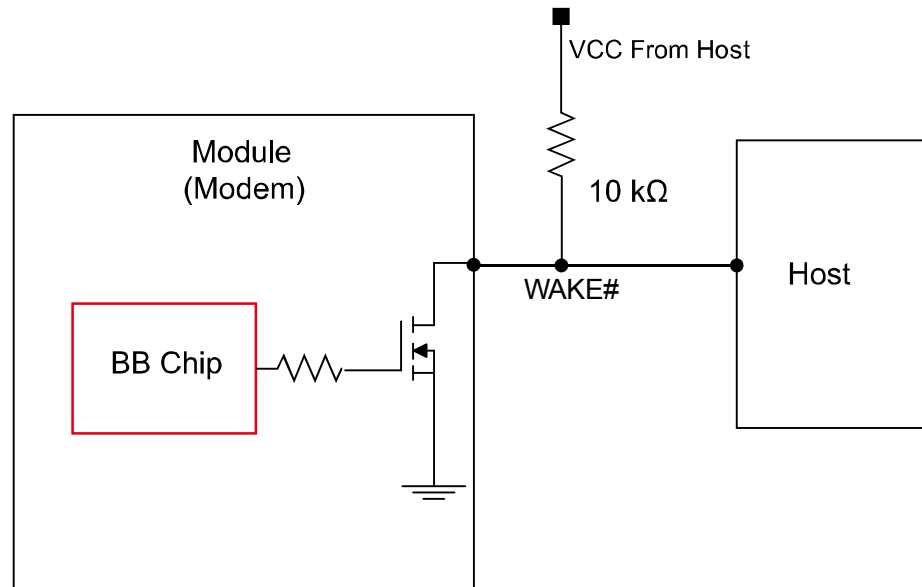

Figure 3-4 Connections of the WAKE# pin



3.4.3 RESIN_N Signal

The RESIN_N pin is used to reset the module's system. When the module software stops responding, the RESIN_N pin can be pulled down to reset the module hardware.

The RESIN_N signal is internally pulled up to 1.8 V, which is automatically on when 3.3 V is applied and it is active-low.

Figure 3-5 Connections of the RESIN_N pin

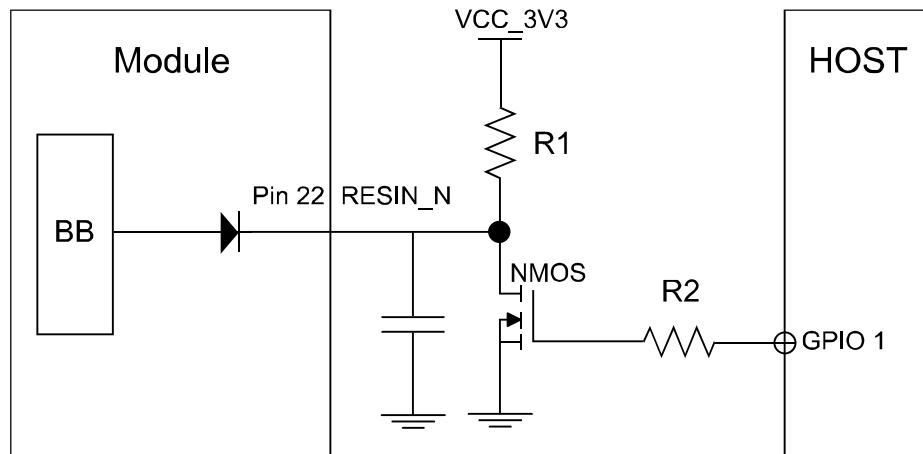

 **CAUTION**

- As the RESIN_N signal is relatively sensitive, it is recommended that you install a 10 nF to 0.1 μF capacitor near the RESIN_N pin of the interface for filtering. In addition, when you design a circuit on the PCB of the interface board, it is recommended that the circuit length should not exceed 20 mm and that the circuit should be kept at a distance of 2.54 mm (100 mil) at least from the PCB edge. Furthermore, you need to wrap the area adjacent to the signal wire with a ground wire. Otherwise, the module may be reset due to interference.
- The maximum Forward Voltage Drop of the diode used in the module is 0.6 V. So when the host wants to reset the module, the low-level-voltage in the RESIN_N pin should below 50 mV.

The ME209u-526 Mini PCIe module supports hardware reset function. If the software of the ME209u-526 Mini PCIe module stops responding, you can reset the hardware through the RESIN_N signal as shown in Figure 3-6 . When a low-level pulse is supplied through the RESIN_N pin, the hardware will be reset. After the hardware is reset, the software starts powering on the module and reports relevant information according to the actual settings. For example, the AT command automatically reports ^SYSSTART.

Figure 3-6 Reset pulse time sequence

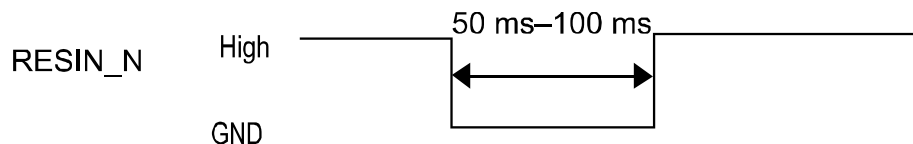



NOTE

- The RESIN_N pin must not be pulled down for more than 1s.
- The RESIN_N pin is optional, which can be not connected.
- The maximum Forward Voltage Drop of the diode used in the module is 0.6 V.

3.4.4 W_DISABLE# Signal

The W_DISABLE# signal is provided to allow users to disable wireless communications of the module.

The firmware does not support this feature yet.

3.4.5 LED_WWAN# Signal

Figure 3-7 shows the recommended circuits of the LED_WWAN# pin. According to LED feature, you can adjust the LED brightness by adjusting the resistance of resistor R.

Table 3-4 State of the LED_WWAN# pin

No.	Operating Status	LED_MODE
1	No service/Restricted service	Outputs: low (0.1s)-high (0.1s)-low (0.1s)-high (1.7s) 2s cycle
2	Register to the network	Outputs: low (0.1s)-high (1.9s) 2s cycle
3	Dial-up successfully	Outputs: low
4	Minimum functionality (AT+CFUN=0)	Outputs: high

Figure 3-7 Driving circuit

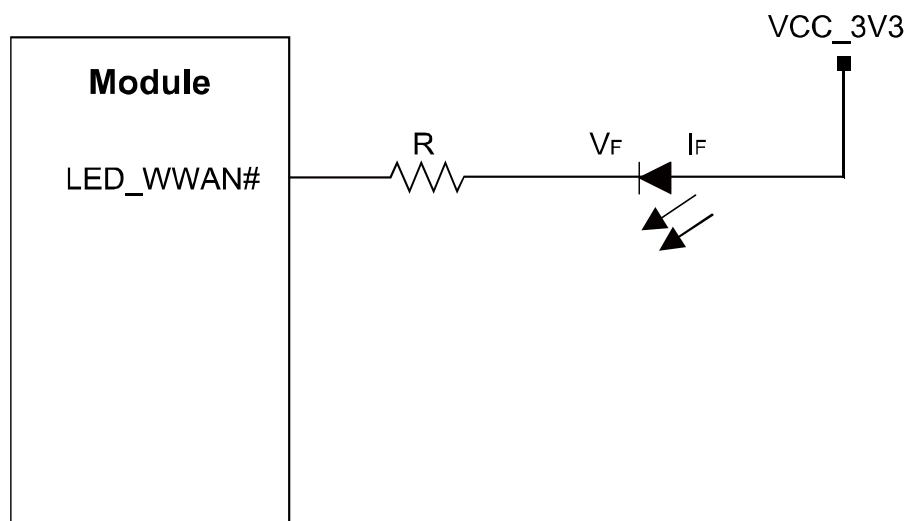

3.5 USB Interface

The ME209u-526 Mini PCIe module is compliant with USB 2.0 protocol. The USB interface is powered directly from the VBAT supply. The USB input/output lines are compatible with the USB 2.0 signal specifications. Figure 3-8 shows the circuit of the USB interface.

Table 3-5 Definition of the USB interface

Pin No.	Pin Name	Pad Type	Description	Min. (V)	Typ. (V)	Max. (V)
36	USB_DM	I/O	USB signal D-	-	-	-
38	USB_DP	I/O	USB signal D+	-	-	-

According to USB protocol, for bus time or electrical characteristics of ME209u-526 USB signal, please refer to the chapter 7.3.2 of [Universal Serial Bus Specification 2.0](#).

Figure 3-8 Recommended circuit of USB interface

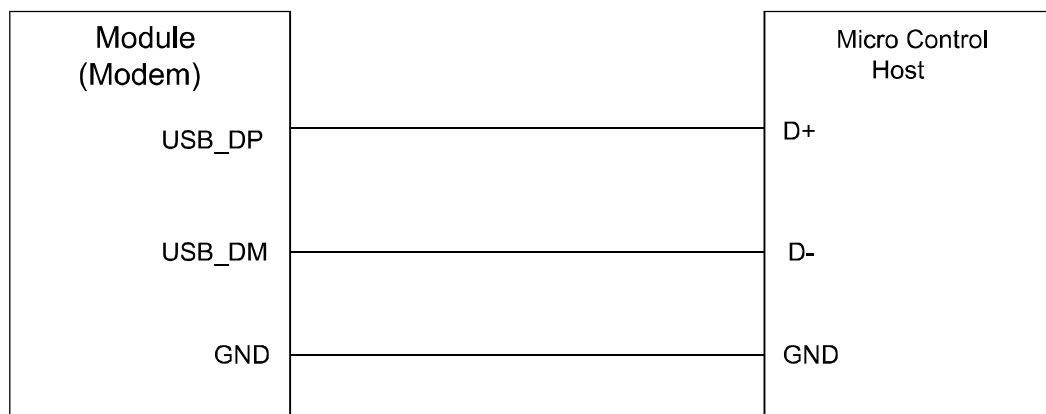

3.6 USIM Card Interface

3.6.1 Overview

The ME209u-526 Mini PCIe module provides a USIM card interface complying with the ISO 7816-3 standard and supports both Class B and Class C USIM cards.

Table 3-6 USIM card interface signals

Pin No.	Pin Name	Pad Type	Description	Parameter	Min. (V)	Typ. (V)	Max.(V)	Comment
14	USIM_RESET	O	External USIM reset signal.	V _{OH}	0.7 x USIM_VCC	-	3.3	USIM_VC C=1.8 V or

Pin No.	Pin Name	Pad Type	Description	Parameter	Min. (V)	Typ. (V)	Max.(V)	Comment
				V _{OL}	0	-	0.2 x USIM_VCC	3.0 V
12	USIM_CLK	O	External USIM clock signal	V _{OH}	0.7 x USIM_VCC	-	3.3	USIM_VC C=1.8 V or 3.0 V
				V _{OL}	0	-	0.2 x USIM_VCC	
10	USIM_DATA	I/O	External USIM data signal	V _{IH}	0.65 x USIM_VCC	-	3.30	USIM_VC C=1.8 V or 3.0 V
				V _{IL}	0	-	0.25 x USIM_VCC	
				V _{OH}	0.7 x USIM_VCC	-	3.3	
				V _{OL}	0	-	0.2 x USIM_VCC	
8	USIM_PWR	PO	Power source for the external USIM card	-	-0.3	1.8	1.98	USIM_VC C=1.8 V
				-	-0.3	2.85	3.3	USIM_VC C=3.0 V

3.6.2 Circuit Recommended for the USIM Card Interface

As the Mini PCIe Adapter is not equipped with a USIM socket, you need to place a USIM socket on the user interface board.

Figure 3-9 shows the circuit of the USIM card interface.

Figure 3-9 Circuit of the USIM card interface

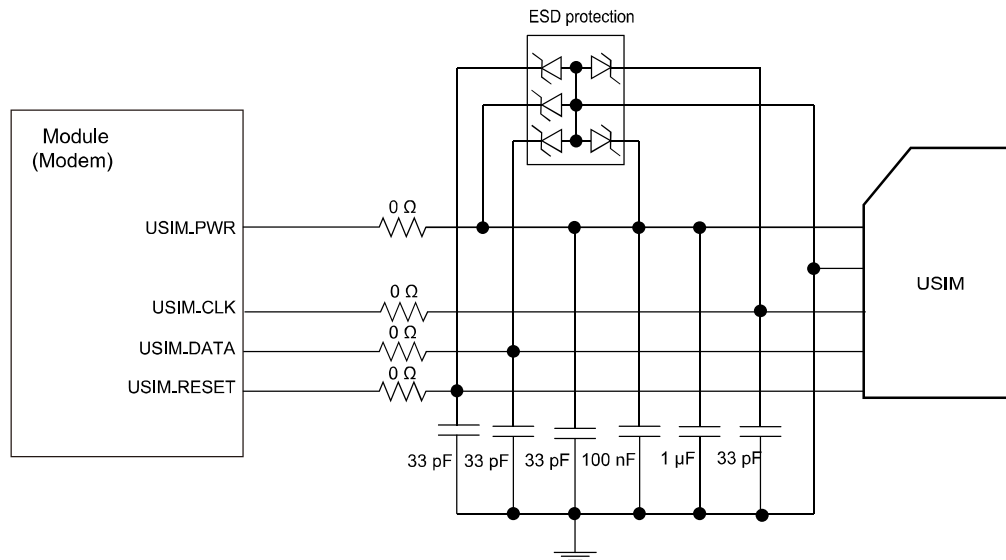

 **CAUTION**

- To meet the requirements of 3GPP TS 51.010-1 protocols and electromagnetic compatibility (EMC) authentication, the USIM socket should be placed near the PCIe interface (it is recommended that the PCB circuit connects the PCIe interface and the USIM socket does not exceed 100 mm), because a long circuit may lead to wave distortion, thus affecting signal quality.
- It is recommended that you wrap the area adjacent to the USIM_CLK and USIM_DATA signal wires with ground. The Ground pin of the USIM socket and the Ground pin of the USIM card must be well connected to the power Ground pin supplying power to the PCIe Adapter.
- A 100 nF capacitor and 1 μF capacitor are placed between the USIM_PWR and GND pins in a parallel manner (If USIM_PWR circuit is too long, that the larger capacitance such as 4.7 μF can be employed if necessary). Three 33 pF capacitors are placed between the USIM_DATA and Ground pins, the USIM_RESET and Ground pins, and the USIM_CLK and Ground pins in parallel to filter interference from RF signals.
- It is recommended to take electrostatic discharge (ESD) protection measures near the USIM card socket. The TVS diode with Vrwm of 5 V and junction capacitance less than 10 pF must be placed as close as possible to the USIM socket, and the Ground pin of the ESD protection component is well connected to the power Ground pin that supplies power to the PCIe Adapter.
- It is not recommended that pull the USIM_DATA pin up during design as a 10000 Ω resistor is used to connect the USIM_DATA pin to the USIM_PWR.

3.7 Audio Interface

The ME209u-526 Mini PCIe module provides one PCM digital audio interface. Table 3-7 lists the signals on the digital audio interface.

The firmware does not support this feature yet.

Table 3-7 Signals on the digital audio interface

Pin No.	Pin Name	Pad Type	Description	Parameter	Min. (V)	Typ. (V)	Max. (V)
45	PCM_CLK	O	PCM interface clock	V_{OL}	-0.3	0	0.45
				V_{OH}	1.35	1.8	2.1
47	PCM_DOUT	O	PCM I/F data out	V_{OL}	-0.3	0	0.45
				V_{OH}	1.35	1.8	2.1
49	PCM_DIN	I	PCM I/F data in	V_{IL}	-0.3	0	0.63
				V_{IH}	1.17	1.8	2.1
51	PCM_SYNC	O	PCM interface sync	V_{OL}	-0.3	0	0.45
				V_{OH}	1.35	1.8	2.1

The ME209u-526 Mini PCIe module interface enables communication with an external codec to support linear format.

Figure 3-10 Circuit diagram of the interface of the PCM (ME209u-526 Mini PCIe module is used as PCM master)

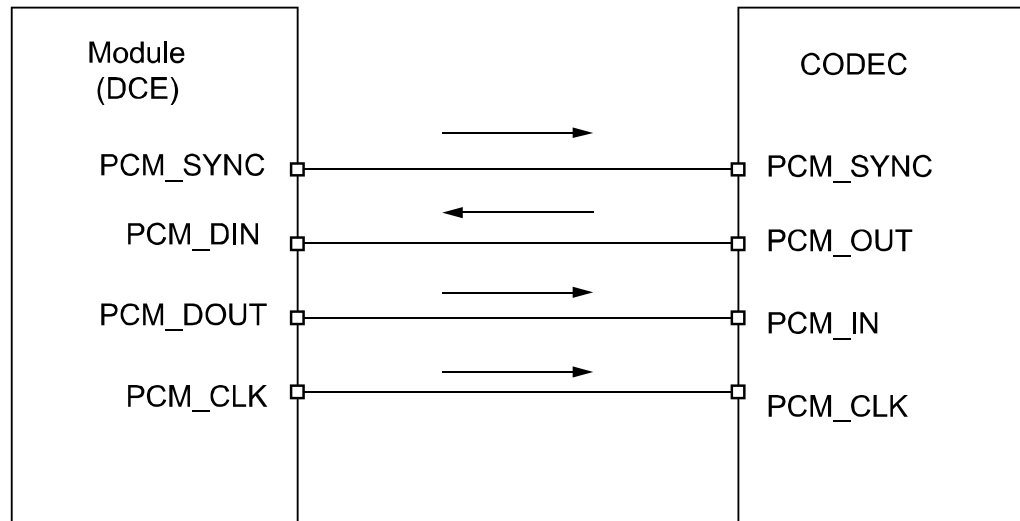

**NOTE**

- PCM_SYNC: Output when PCM is in master mode.
- PCM_CLK: Output when PCM is in master mode.
- It is recommended that a TVS be used on the related interface, to prevent electrostatic discharge and protect integrated circuit (IC) components.

3.8 NC Pins

The ME209u-526 Mini PCIe module has some NC pins. All of NC pins should not be connected. Please keep these pins open.

Table 3-8 NC pins

Pin No.	Pin Name	Pad Type	Description
3, 5 6, 7, 11, 13, 16, 17, 19 23, 25, 28, 30–33, 44, 46 and 48	NC	-	Not connected, please keep open.

4 RF Specifications

4.1 About This Chapter

This chapter describes the RF specifications of the ME209u-526 Mini PCIe module, including:

- Operating Frequencies
- Conducted RF Measurement
- Conducted Rx Sensitivity and Tx Power
- Antenna Design Requirements

4.2 Operating Frequencies

Table 4-1 shows the RF bands supported by the ME209u-526 Mini PCIe module.

Table 4-1 RF bands of ME209u-526 Mini PCIe

Operating Band	Tx	Rx
LTE Band 4	1710 MHz–1755 MHz	2110 MHz–2155 MHz
LTE Band 13	777 MHz–787 MHz	746 MHz–756 MHz

4.3 Conducted RF Measurement

4.3.1 Test Environment

Test instrument	R&S CMW500, Anritsu MT8820C
Power supply	Keithley 2303, Agilent 66319
RF cable for testing	L08-C014-350 of DRAKA COMTEQ or Rosenberger Cable length: 29 cm



NOTE

- The compensation for different frequency bands relates to the cable and the test environment.
- The instrument compensation needs to be set according to the actual cable conditions.

4.3.2 Test Standards

Huawei modules meet 3GPP test standards. Each module passes strict tests at the factory and thus the quality of the modules is guaranteed.

4.4 Conducted Rx Sensitivity and Tx Power

4.4.1 Conducted Receive Sensitivity

The conducted receive sensitivity is a key parameter that indicates the receiver performance of ME209u-526 Mini PCIe module.

Table 4-2 lists the typical tested values of the ME209u-526 Mini PCIe module.

Table 4-2 ME209u-526 Mini PCIe module conducted Rx sensitivity (unit: dBm)

Band	Typical Value	Note
LTE Band 4 RX	-102	Throughput ≥ 95%, 10 MHz Bandwidth
LTE Band 13 RX	-102	Throughput ≥ 95%, 10 MHz Bandwidth



NOTE

- The test values are the average of some test samples.
- LTE sensitivity is tested in SIMO (Main+AUX).

4.4.2 Conducted Transmit Power

The conducted transmit power is another indicator that measures the performance of ME209u-526 Mini PCIe module. The conducted transmit power refers to the maximum power that the module tested at the antenna connector can transmit. According to the 3GPP protocol, the required transmit power varies with the power class.

Table 4-3 lists the typical tested values of the ME209u-526 Mini PCIe module.

Table 4-3 ME209u-526 Mini PCIe module conducted Tx power (unit: dBm)

Band	Typical Value	Note
LTE Band 4	22.5	-1/+1.5 dB
LTE Band 13	22.5	-1/+1.5 dB

**NOTE**

Maximum Power Reduction (MPR) of LTE is according to 3GPP TS 36.521-1. And Additional Maximum Power Reduction (A-MPR) of LTE is according to 3GPP TS 36.521-1 6.2.4 section.

4.5 Antenna Design Requirements

4.5.1 Antenna Design Indicators

Antenna Efficiency

Antenna efficiency is the ratio of the input power to the radiated or received power of an antenna. The radiated power of an antenna is always lower than the input power due to the following antenna losses: return loss, material loss, and coupling loss. The efficiency of an antenna relates to its electrical dimensions. To be specific, the antenna efficiency increases with the electrical dimensions. In addition, the transmission cable from the antenna connector of PCIe Adapter to the antenna is also part of the antenna. The cable loss increases with the cable length and the frequency. It is recommended that the cable loss is as low as possible, for example, U.FL-LP-088 made by HRS.

The following antenna efficiency (free space) is recommended for ME209u-526 Mini PCIe module to ensure high radio performance of the module:

- Efficiency of the primary antenna: $\geq 40\%$ (below 960 MHz); $\geq 50\%$ (over 1710 MHz)
- Efficiency of the diversity antenna: \geq half of the efficiency of the primary antenna in receiving band

In addition, the efficiency should be tested with the transmission cable.

S11 or VSWR

S11 indicates the degree to which the input impedance of an antenna matches the reference impedance (50 Ω). S11 shows the resonance feature and impedance bandwidth of an antenna. Voltage standing wave ratio (VSWR) is another expression of S11. S11 relates to the antenna efficiency. S11 can be measured with a vector analyzer.

The following S11 value is recommended for the antenna of ME209u-526 Mini PCIe module:

- S11 of the primary antenna: ≤ -6 dB
- S11 of the diversity antenna: ≤ -6 dB

In addition, S11 is less important than the efficiency, and S11 has weak correlation to wireless performance.

Isolation

For a wireless device with multiple antennas, the power of different antennas is coupled with each other. Antenna isolation is used to measure the power coupling. The power radiated by an antenna might be received by an adjacent antenna, which decreases the antenna radiation efficiency and affects the running of other devices. To

avoid this problem, evaluate the antenna isolation as sufficiently as possible at the early stage of antenna design.

Antenna isolation depends on the following factors:

- Distance between antennas
- Antenna type
- Antenna direction

The primary antenna must be placed as near as possible to the ME209u-526 Mini PCIe module to minimize the cable length. The diversity antenna needs to be installed perpendicularly to the primary antenna. The diversity antenna can be placed farther away from the ME209u-526 Mini PCIe module. Antenna isolation can be measured with a two-port vector network analyzer.

The following antenna isolation is recommended for the antennas on laptops:

- Isolation between the primary and diversity antennas: ≤ -12 dB
- Isolation between the primary antenna and the Wi-Fi antenna: ≤ -15 dB

Polarization

The polarization of an antenna is the orientation of the electric field vector that rotates with time in the direction of maximum radiation.

The linear polarization is recommended for the antenna of ME209u-526 Mini PCIe module.

Radiation Pattern

The radiation pattern of an antenna reflects the radiation features of the antenna in the remote field region. The radiation pattern of an antenna commonly describes the power or field strength of the radiated electromagnetic waves in various directions from the antenna. The power or field strength varies with the angular coordinates (θ and φ), but is independent of the radial coordinates.

The radiation pattern of half wave dipole antennas is omnidirectional in the horizontal plane, and the incident waves of base stations are often in the horizontal plane. For this reason, the receiving performance is optimal.

The following radiation patterns are recommended for the antenna of ME209u-526 Mini PCIe module.

Primary/Diversity antenna: omnidirectional

In addition, the diversity antenna's pattern should be complementary with the primary's.

Envelope Correlation Coefficient

The envelope correlation coefficient indicates the correlation between different antennas in a multi-antenna system (primary antenna, diversity antenna, and MIMO antenna). The correlation coefficient shows the similarity of radiation patterns, that is, amplitude and phase, of the antennas. The ideal correlation coefficient of a diversity antenna system or a MIMO antenna system is 0. A small value of the envelope correlation coefficient between the primary antenna and the diversity antenna

indicates a high diversity gain. The envelope correlation coefficient depends on the following factors:

- Distance between antennas
- Antenna type
- Antenna direction

The antenna correlation coefficient differs from the antenna isolation. Sufficient antenna isolation does not represent a satisfactory correlation coefficient. For this reason, the two indicators need to be evaluated separately.

For the antennas on laptops, the recommended envelope correlation coefficient between the primary antenna and the diversity antenna is smaller than 0.5.

Gain and Directivity

The radiation pattern of an antenna represents the field strength of the radiated electromagnetic waves in all directions, but not the power density that the antenna radiates in the specific direction. The directivity of an antenna, however, measures the power density that the antenna radiates.

Gain, as another important parameter of antennas, correlates closely to the directivity. The gain of an antenna takes both the directivity and the efficiency of the antenna into account. The appropriate antenna gain prolongs the service life of relevant batteries.

The following antenna gain is recommended for ME209u-526 Mini PCIe module.

Gain of the primary/diversity antenna ≤ 2.5 dBi



NOTE

- The antenna consists of the antenna body and the relevant RF transmission cable. Take the RF transmission cable into account when measuring any of the preceding antenna indicators.
- Huawei cooperates with various famous antenna suppliers who are able to make suggestions on antenna design, for example, Amphenol, Skycross, etc.

4.5.2 Interference

Besides the antenna performance, the interference on the user board also affects the radio performance (especially the TIS) of the module. To guarantee high performance of the module, the interference sources on the user board must be properly controlled.

On the user board, there are various interference sources, such as the LCD, CPU, audio circuits, and power supply. All the interference sources emit interference signals that affect the normal operation of the module. For example, the module sensitivity can be decreased due to interference signals. Therefore, during the design, you need to consider how to reduce the effects of interference sources on the module. You can take the following measures: Use an LCD with optimized performance; shield the LCD interference signals; shield the signal cable of the board; or design filter circuits.

Huawei is able to make technical suggestions on radio performance improvement of the module.

4.5.3 Antenna Requirements

The antenna for ME209u-526 Mini PCIe module must fulfill the following requirements:

Antenna Requirements	
Frequency range	Depending on frequency band(s) provided by the network operator, the customer must use the most suitable antenna for that/those band(s)
Bandwidth of primary antenna	45 MHz in RX or TX band in LTE Band 4 41 MHz in LTE Band 13
Bandwidth of secondary antenna	45 MHz in LTE Band 4 10 MHz in LTE Band 13
Gain of primary/secondary antenna	≤ 2.5 dBi
Impedance	50 Ω
VSWR absolute max	≤ 3:1
VSWR recommended	≤ 2:1

5 Electrical and Reliability Features

5.1 About This Chapter

This chapter describes the electrical and reliability features of the interfaces in the ME209u-526 Mini PCIe module, including:

- Absolute Ratings
- Operating and Storage Temperatures
- Power Supply Features
- Reliability Features
- EMC and ESD Features

5.2 Absolute Ratings



WARNING

Table 5-1 lists the absolute ratings for the ME209u-526 Mini PCIe module. Using the module beyond these conditions may result in permanent damage to the module.

Table 5-1 Absolute ratings for the ME209u-526 Mini PCIe module

Symbol	Specification	Min.	Max.	Unit
VCC_3V3	External power voltage	-0.3	4.0	V

5.3 Operating and Storage Temperatures

Table 5-2 lists the operating and storage temperatures for the ME209u-526 Mini PCIe module.

Table 5-2 Operating and storage temperatures for the ME209u-526 Mini PCIe module

Specification	Min.	Max.	Unit
Normal working temperatures	-30	+70	°C
Extended temperatures ^[1]	-40	+75	°C
Ambient temperature for storage	-40	+85	°C



NOTE

[1]: When the ME209u-526 Mini PCIe module works in the range of -40°C to -30°C or +70°C to +75°C, **NOT** all its RF performances comply with 3GPP specifications. The thermal design must be implemented according to the chapter 6.7. If not, the overheat protection mechanism will be triggered due to overheated Mini PCIe and the network connection will be terminated.

5.4 Power Supply Features

5.4.1 Input Power Supply

Table 5-3 lists the requirements for input power of the ME209u-526 Mini PCIe module.

Table 5-3 Requirements for input power for the ME209u-526 Mini PCIe module

Parameter	Min.	Typ.	Max.	Ripple	Unit
VCC_3V3	3.0	3.3	3.6	0.05	V

Figure 5-1 Power Supply During Burst Emission

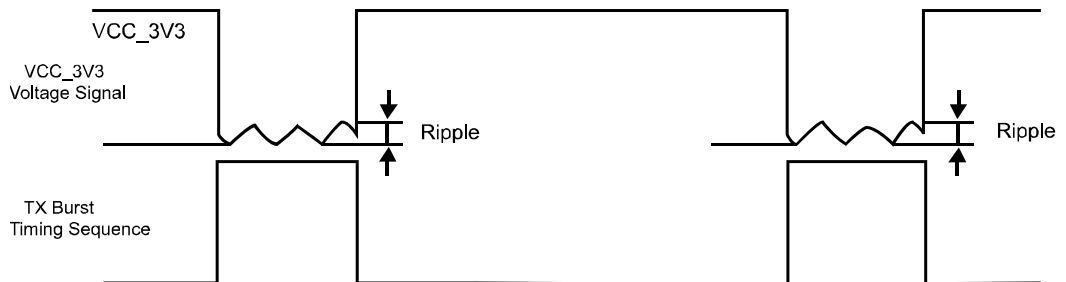

NOTE

The VCC_3V3 minimum value must be guaranteed during the burst. So A low-dropout (LDO) regulator or switch power with current output of more than 3.5 A is strongly recommended for external power supply.

Table 5-4 Requirements for input current of the ME209u-526 Mini PCIe module

Power	Peak (Maximum) Max Avg@100uS	Normal (Maximum) Max Avg@1S
VBAT (3.3 V)	1 A	860 mA

5.4.2 Power Consumption

The power consumption of ME209u-526 Mini PCIe module in different scenarios are respectively listed in Table 5-5 and Table 5-6 .

The power consumption listed in this section are tested when the power supply of ME209u-526 Mini PCIe module is normal voltage (3.3 V), and all of test values are measured at room temperature.

Table 5-5 Averaged standby DC power consumption of ME209u-526 Mini PCIe Module

Description		Bands	Test Value (mA)	Notes/Configuration
			Typical	
Sleep	LTE	LTE bands	2.92	Module is powered up. DRX cycle=8 (2.56s) Module is registered on the network. USB is in suspend.
Idle	LTE	LTE bands	47	Module is powered up. DRX cycle=8 (2.56s) Module is registered on the network, and no data is transmitted. USB is in active.

Table 5-6 Averaged Data Transmission DC power consumption of ME209u-526 Mini PCIe module

Description	Band	Test Value	Units	Power (dBm)
LTE	LTE Band 4	414	mA	0 dBm Tx Power
		467		10 dBm Tx Power
		720		23 dBm Tx Power
	LTE Band 13	376	mA	0 dBm Tx Power
		430		10 dBm Tx Power
		688		23 dBm Tx Power

5.5 Reliability Features

Table 5-7 lists the test conditions and results of the reliability of the ME209u-526 Mini PCIe module.

Table 5-7 Test conditions and results of the reliability of the ME209u-526 Mini PCIe module

Item		Test Condition	Standard	Sample size	Results
Stress	Low-temperature storage	<ul style="list-style-type: none"> Temperature: -40°C Operation mode: no power, no package Test duration: 24 h 	JESD22-A119-C	3 pcs/group	Visual inspection: ok Function test: ok RF specification: ok
	High-temperature storage	<ul style="list-style-type: none"> Temperature: 85°C Operation mode: no power, no package Test duration: 24 h 	JESD22-A103-C	3 pcs/group	Visual inspection: ok Function test: ok RF specification: ok
	Low-temperature operating	<ul style="list-style-type: none"> Temperature: -40°C Operation mode: working with service connected Test duration: 24 h 	IEC60068-2-1	3 pcs/group	Visual inspection: ok Function test: ok RF specification: ok
	High-temperature operating	<ul style="list-style-type: none"> Temperature: 75°C Operation mode: working with service connected Test duration: 24 h 	JESD22-A108-C	3 pcs/group	Visual inspection: ok Function test: ok RF specification: ok
	Temperature cycle operating	<ul style="list-style-type: none"> High temperature: 75°C Low temperature: -40°C Operation mode: working with service connected Test duration: 30 cycles; 1 h+1 h/cycle 	JESD22-A105-B	3 pcs/group	Visual inspection: ok Function test: ok RF specification: ok
	Damp heat cycling	<ul style="list-style-type: none"> High temperature: 55°C Low temperature: 25°C Humidity: 95%±3% Operation mode: working with service connected Test duration: 6 cycles; 12 h+12 h/cycle 	JESD22-A101-B	3 pcs/group	Visual inspection: ok Function test: ok RF specification: ok

Item	Test Condition	Standard	Sample size	Results
Thermal shock	<ul style="list-style-type: none"> • Low temperature: -40°C • High temperature: 85°C • Temperature change interval: < 20s • Operation mode: no power • Test duration: 100 cycles; 15 min+15 min/cycle 	JESD22-A106-B	3 pcs/group	Visual inspection: ok Function test: ok RF specification: ok
Salty fog test	<ul style="list-style-type: none"> • Temperature: 35°C • Density of the NaCl solution: 5%±1% • Operation mode: no power, no package • Test duration: Spraying interval: 8 h Exposing period after removing the salty fog environment: 16 h 	JESD22-A107-B	3 pcs/group	Visual inspection: ok Function test: ok RF specification: ok
Sine vibration	<ul style="list-style-type: none"> • Frequency range: 5 Hz to 200 Hz • Acceleration: 1 Grms • Frequency scan rate: 0.5 oct/min • Operation mode: working with service connected • Test duration: 3 axial directions. 2 h for each axial direction. 	JESD22-B103-B	3 pcs/group	Visual inspection: ok Function test: ok RF specification: ok
Shock test	<ul style="list-style-type: none"> • Half-sine wave shock • Peak acceleration: 30 Grms • Shock duration: 11 ms • Operation mode: working with service connected • Test duration: 6 axial directions. 3 shocks for each axial direction. 	JESD-B104-C	3 pcs/group	Visual inspection: ok Function test: ok RF specification: ok

Item		Test Condition	Standard	Sample size	Results
	Drop test	<ul style="list-style-type: none"> 0.8 m in height. Drop the module on the marble terrace with one surface facing downwards, six surfaces should be tested. Operation mode: no power, no package 	IEC6006 8-2-32	3 pcs/group	Visual inspection: ok Function test: ok RF specification: ok
Life	High temperature operating life	<ul style="list-style-type: none"> Temperature: 75°C Operation mode: working with service connected Test duration: 168 h, 336 h, 500 h for inspection point 	JESD22-A108-B	50 pcs/group	Visual inspection: ok Function test: ok RF specification: ok
	High temperature & high humidity	<ul style="list-style-type: none"> High temperature: 85°C Humidity: 85% Operation mode: powered on and no working Test duration: 168 h, 336 h, 500 h, 1000 h for inspection point 	JESD22-A110-B	50 pcs/group	Visual inspection: ok Function test: ok RF specification: ok Cross section: ok
	Temperature cycle-Non operating	<ul style="list-style-type: none"> High temperature: 85°C Low temperature: -40°C Temperature change slope: 6°C/min Operation mode: no power Test duration: 168 h, 336 h, 500 h, 668 cycle for inspection point 	JESD22-A104-C	50 pcs/group	Visual inspection: ok Function test: ok RF specification: ok Cross section: ok
ESD	HBM (Human Body Model)	<ul style="list-style-type: none"> 1 kV (Class 1 B) Operation mode: no power 	JESD22-A114-D	3 pcs/group	Visual inspection: ok Function test: ok RF specification: ok
	ESD with DVK (or embedded in the host)	<ul style="list-style-type: none"> Contact Voltage: ±2 kV, ±4 kV Air Voltage : ±2 kV, ±4 kV, ±8 kV Operation mode: working with service connected 	IEC6100 0-4-2	2 pcs	Visual inspection: ok Function test: ok RF specification: ok
 NOTE Groups ≥ 2					

5.6 EMC and ESD Features

The following are the EMC design comments:

- Attention should be paid to static control in the manufacture, assembly, packaging, handling, and storage process to reduce electrostatic damage to HUAWEI module.
- RSE (Radiated Spurious Emission) may exceed the limit defined by EN301489 if the antenna port is protected by TVS (Transient Voltage Suppressor), which is resolved by making some adjustments on RF match circuit.
- TVS should be added on the USB port for ESD protection, and the parasitic capacitance of TVS on D+/D- signal should be less than 2 pF. Common-mode inductor should be added in parallel on D+/D- signal.
- TVS should be added on the USIM interface for ESD protection. The parasitic capacitance of TVS on USIM signal should be less than 10 pF.
- Resistors in parallel and a 10 nF capacitor should be added on RESIN_N to avoid shaking, and the distance between the capacitor and the related pin should be less than 100 mil.
- PCB routing should be V-type rather than T-type for TVS.
- An integrated ground plane is necessary for EMC design.

The following are the requirements of ESD environment control:

- The electrostatic discharge protected area (EPA) must have an ESD floor whose surface resistance and system resistance are greater than $1 \times 10^4 \Omega$ while less than $1 \times 10^9 \Omega$.
- The EPA must have a sound ground system without loose ground wires, and the ground resistance must be less than 4 Ω .
- The workbench for handling ESD sensitive components must be equipped with common ground points, the wrist strap jack, and ESD pad. The resistance between the jack and common ground point must be less than 4 Ω . The surface resistance and system resistance of the ESD pad must be less than $1 \times 10^9 \Omega$.
- The EPA must use the ESD two-circuit wrist strap, and the wrist strap must be connected to the dedicated jack. The crocodile clip must not be connected to the ground.
- The ESD sensitive components, the processing equipment, test equipment, tools, and devices must be connected to the ground properly. The indexes are as follows:
 - Hard ground resistance < 4 Ω
 - $1 \times 10^5 \Omega \leq$ Soft ground resistance < $1 \times 10^9 \Omega$
 - $1 \times 10^5 \Omega \leq$ ICT fixture soft ground resistance < $1 \times 10^{11} \Omega$
 - The electronic screwdriver and electronic soldering iron can be easily oxidized. Their ground resistance must be less than 20 Ω .
- The parts of the equipment, devices, and tools that touch the ESD sensitive components and moving parts that are close to the ESD sensitive components must be made of ESD materials and have sound ground connection. The parts that are not made of ESD materials must be handled with ESD treatment, such as painting the ESD coating or ionization treatment (check that the friction voltage is less than 100 V).

- Key parts in the production equipment (parts that touch the ESD sensitive components or parts that are within 30 cm away from the ESD sensitive components), including the conveyor belt, conveyor chain, guide wheel, and SMT nozzle, must all be made of ESD materials and be connected to the ground properly (check that the friction voltage is less than 100 V).
- Engineers that touch IC chips, boards, modules, and other ESD sensitive components and assemblies must wear ESD wrist straps, ESD gloves, or ESD finger cots properly. Engineers that sit when handling the components must all wear ESD wrist straps.
- Noticeable ESD warning signs must be attached to the packages and placement areas of ESD sensitive components and assemblies.
- Boards and IC chips must not be stacked randomly or be placed with other ESD components.



NOTE

HUAWEI ME209u-526 Mini PCIe module does not include any protection against overvoltage.

6 Mechanical Specifications

6.1 About This Chapter

This chapter mainly describes mechanical specifications of ME209u-526 Mini PCIe module, including:

- Dimensions and Interfaces
- Dimensions of the Mini PCI Express Connector
- Packaging
- Specification Selection for Fasteners
- Antenna Plug
- Thermal Design Guide

6.2 Dimensions and Interfaces

The dimensions of the ME209u-526 Mini PCIe module are 51 mm (length) × 30.4 mm (width) × 3.4 mm (height). Figure 6-1 shows the dimensions of ME209u-526 Mini PCIe module in detail.

Figure 6-1 Dimensions of the ME209u-526 Mini PCIe module (unit: mm)

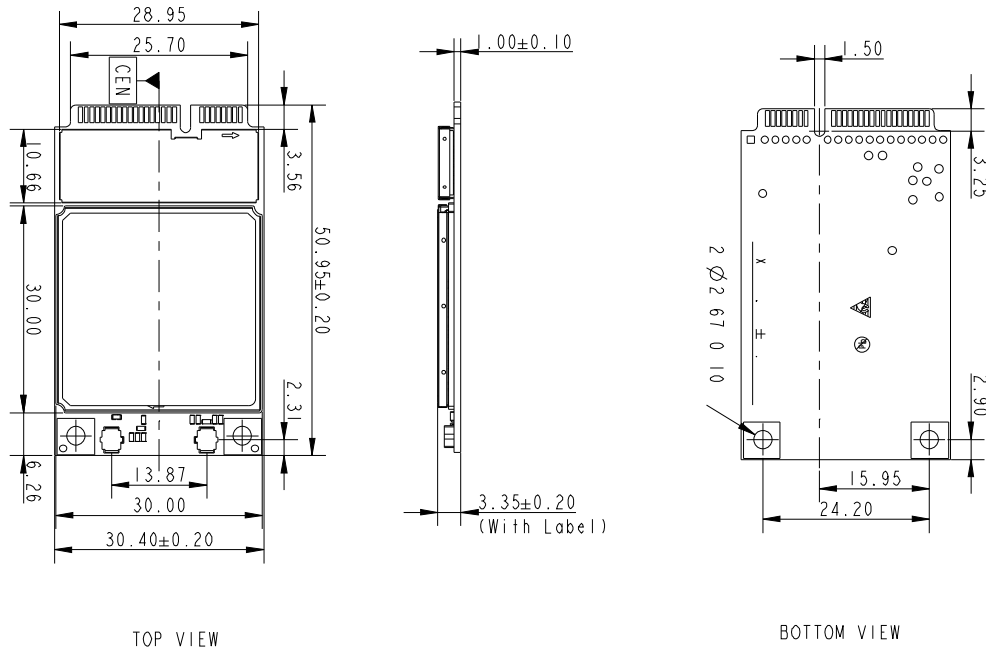

6.3 Dimensions of the Mini PCI Express Connector

The Mini PCIe Adapter adopts a standard Mini PCI Express connector that has 52 pins and complies with the *PCI Express Mini Card Electromechanical Specification Revision 1.2*.

Figure 6-2 shows a 52-pin Mini PCI Express connector (take the Molex 67910002 as an example).

Figure 6-2 Dimensions of the Mini PCI Express connector (unit: mm)

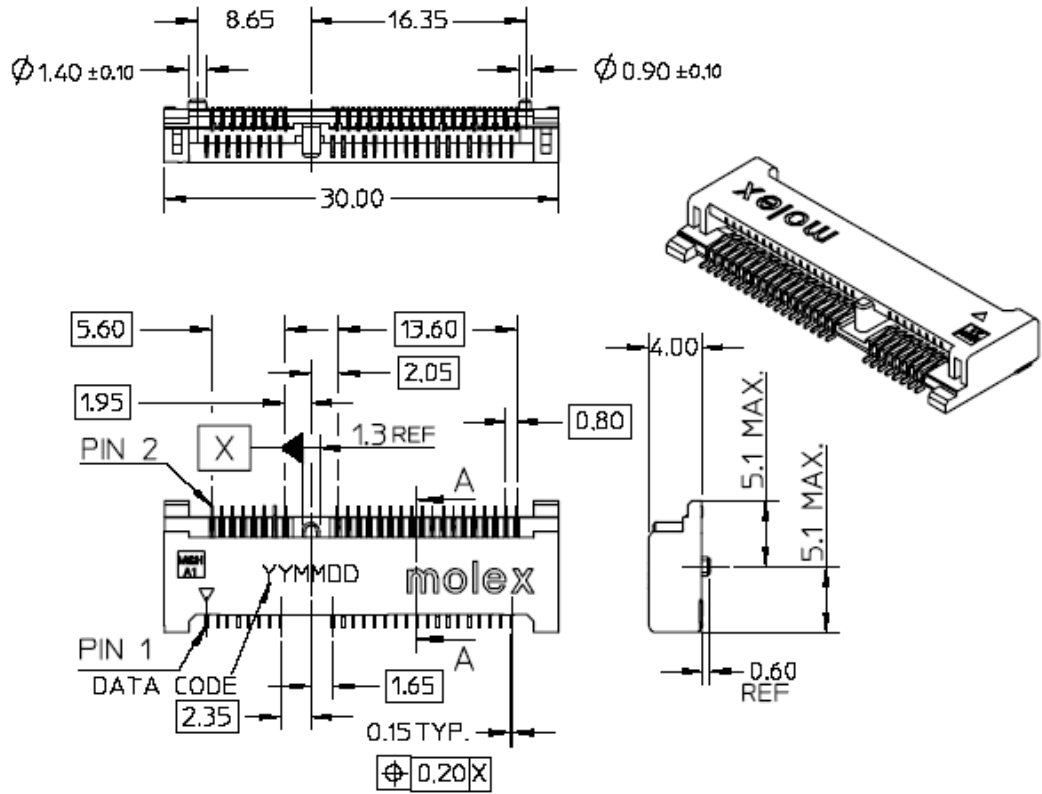

6.4 Packaging

HUAWEI Mini PCIe module uses anti-vibration foam and ESD bag into cartons.

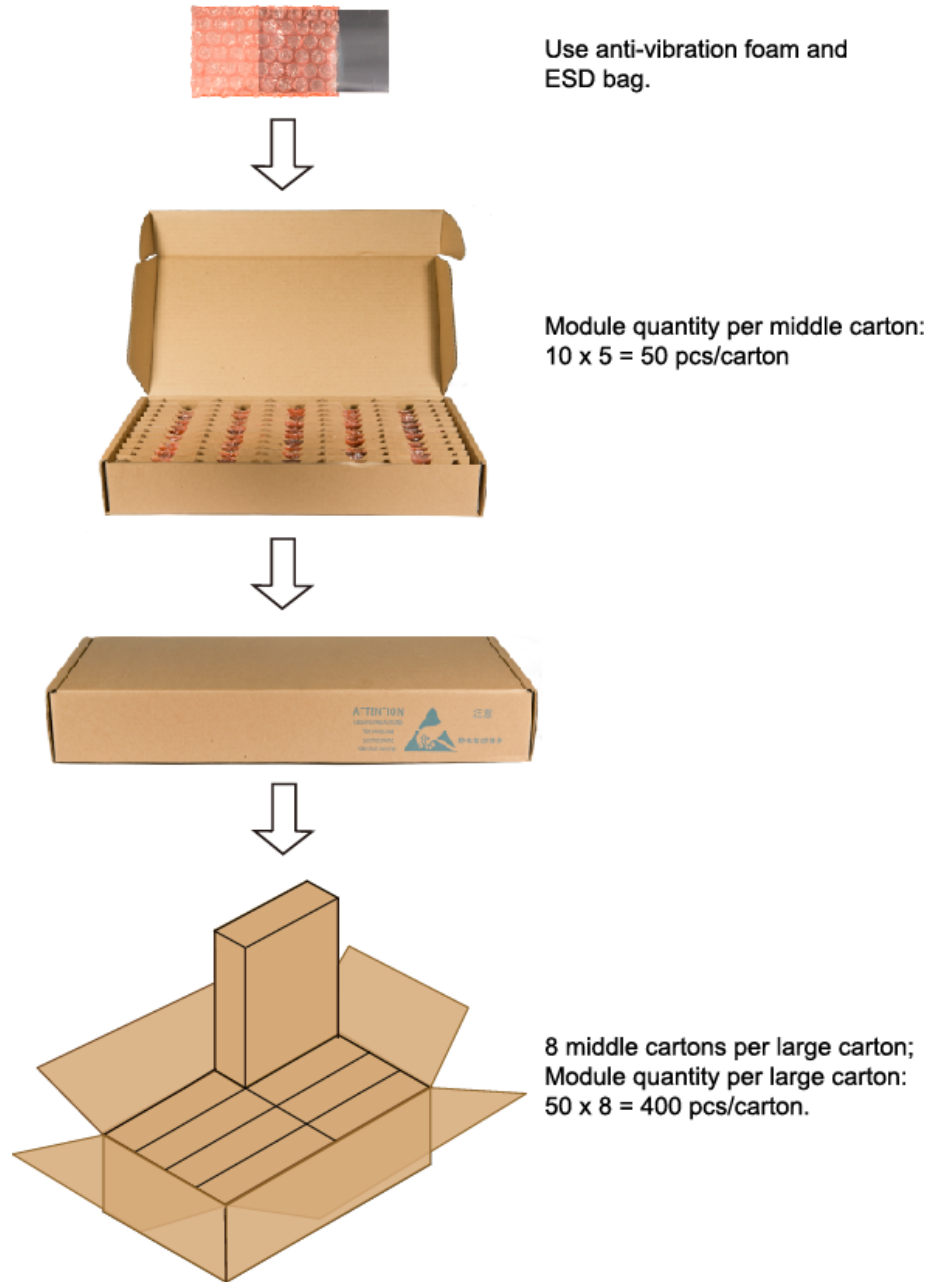

6.5 Specification Selection for Fasteners

6.5.1 Installing the Mini PCIe Adapter on the Main Board

To install the Mini PCIe Adapter on the main board, do the following:

Step 1 Insert the Mini PCIe Adapter into the Mini PCI Express connector on the main board.

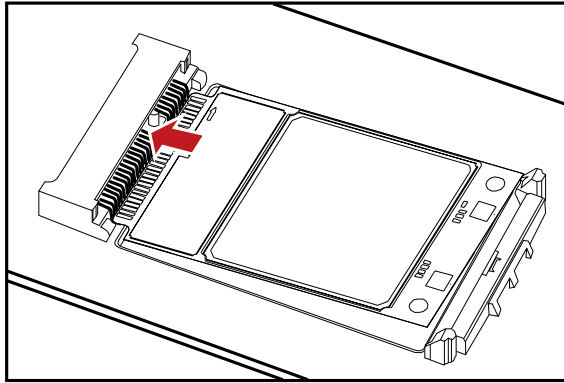

Step 2 Press downwards to fix the Mini PCIe Adapter in the module slot.

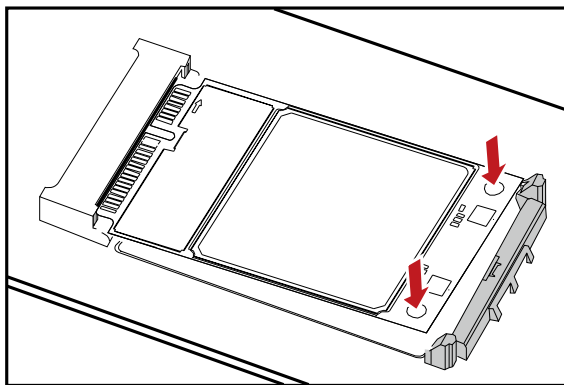

Step 3 Use a screwdriver to fix the Mini PCIe Adapter on the main board with two screws provided in the Mini PCIe Adapter packing box.

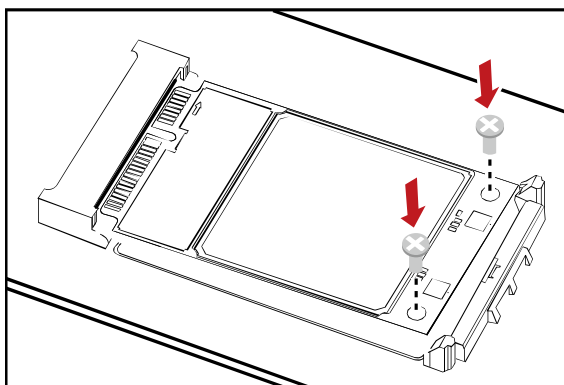

Step 4 Insert the connector of the main antenna into the MAIN antenna interface (M) of the Mini PCIe Adapter according to the indication on the label of the Mini PCIe Adapter. Insert the connector of the auxiliary antenna into the AUX antenna interface (A) of the Mini PCIe Adapter.

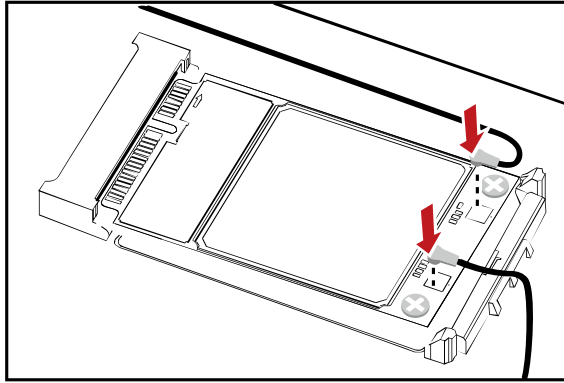

NOTE

- Insert the antenna connectors vertically into the antenna interfaces of the Mini PCIe Adapter.
- Do not press or squeeze the antenna cable or damage the connectors. Otherwise, the wireless performance of the Mini PCIe Adapter may be reduced or the Mini PCIe Adapter cannot work normally.
- Ensure that the antenna cables are routed through the channel in the frame of the PC and do not lay the cables across the raised edges of the frame.
- The module could not be installed or removed when the host is powered on. Otherwise, it may result in permanent damage to the module.

6.5.2 Removing the Mini PCIe Adapter from the Main Board

Step 1 Disconnect the antenna cables from the Mini PCIe Adapter. You can lift the connectors using a small screwdriver.

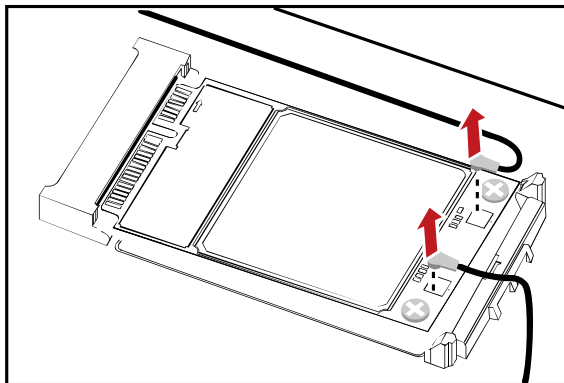

Step 2 Remove the two screws with the screwdriver.

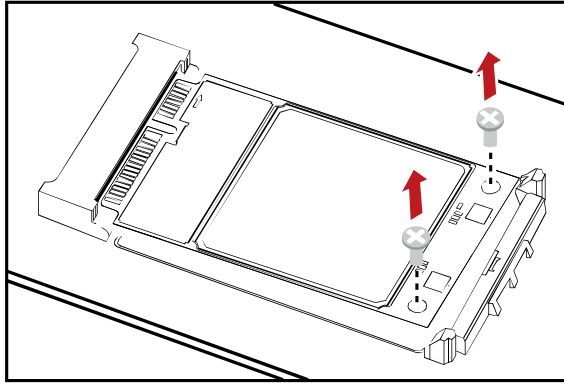

Step 3 Slide backwards the two clips to release the Mini PCIe Adapter from the slot. Then, lift up the Mini PCIe Adapter.

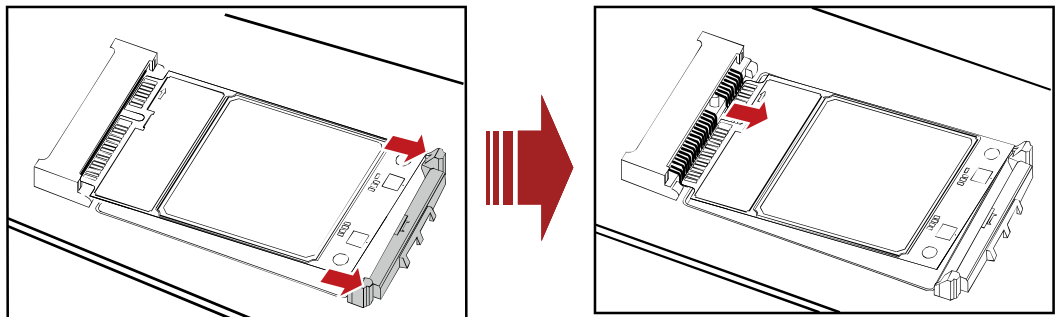

6.6 Antenna Plug

Figure 6-3 Mating the plug

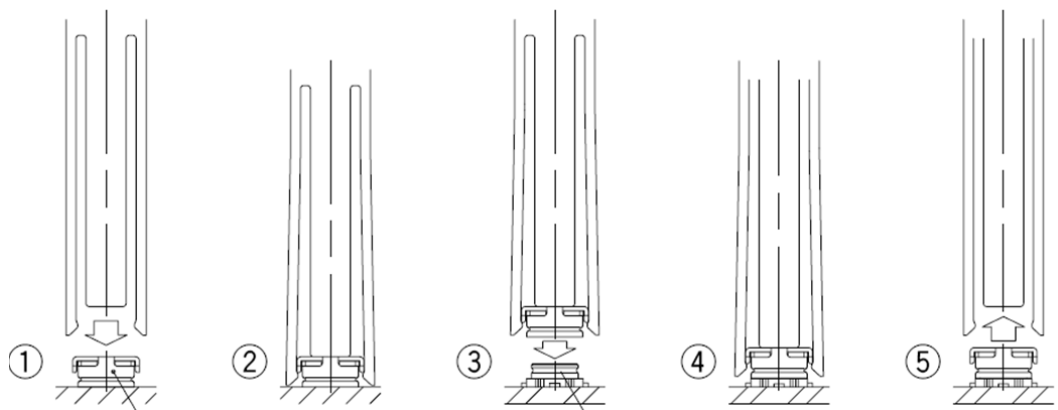

1. Align the mating tool or the mating end of the tool over the plug end of the cable assembly.
2. Firmly place the tool over the plug until it is secured in the tool.

3. Place the plug cable assembly (held in the tool) over the corresponding receptacle.
4. Assure that the plug and receptacle are aligned press-down perpendicular to the mounting surface until both connectors are fully mated.
5. Remove the mating tool by pulling it up carefully.

Figure 6-4 Unmating the plug

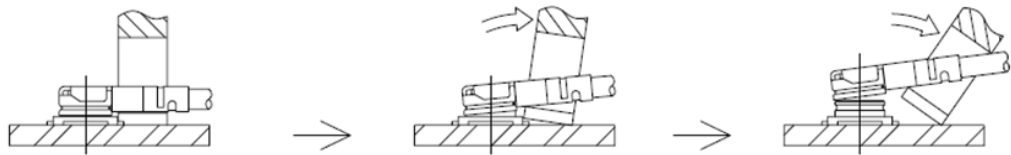

NOTE

- The extraction tool is recommended.
- Any attempt of unmating by pulling on the cable may result in damage and influence the mechanical/electrical performance.

It is recommended not to apply any pull forces after the bending of the cable, as described in Figure 6-5 .

Figure 6-5 Do not apply any pull forces after the bending of the cable

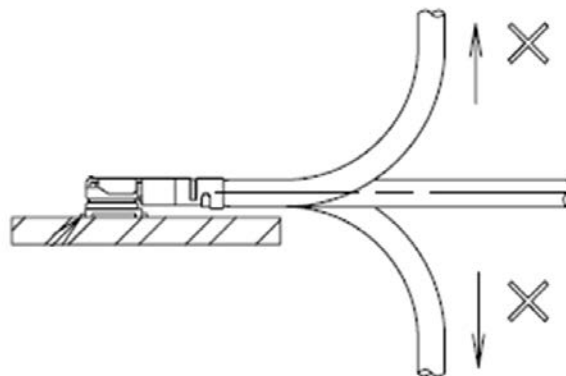

6.7 Thermal Design Guide

When using in the LTE network, the ME209u-526 Mini PCIe module has high power consumption (for details, see Table 5-6). To improve the module reliability and stability, focus on the thermal design of the device to speed up heat dissipation.

Take the following heat dissipation measures:

- Do not hollow out the customer PCB.
- Attach the thermal conductive material between the Mini PCIe and the customer PCB. The recommended thermal conductivity of the thermal conductive material is 1.0 W/m-k or higher (recommended manufacturers: Laird and Bergquist). The

dimensions (W x D) of the thermal conductive material are 38 mm x 28 mm (1.50 in. x 1.10 in.), and its height depends on the height of the Mini PCIe connector you use and the method for installing the Mini PCIe. When deciding the height of the thermal conductive material, you are advised to obey the following rule: After the Mini PCIe is fastened to the customer PCB, the compression amount of the thermal conductive material accounts for 15% to 30% of the thermal conductive material size. For example, if you use a connector shown in the following figure and install the Mini PCIe like this, the recommended height of the thermal conductive material is 1.8 mm (0.07 in.).

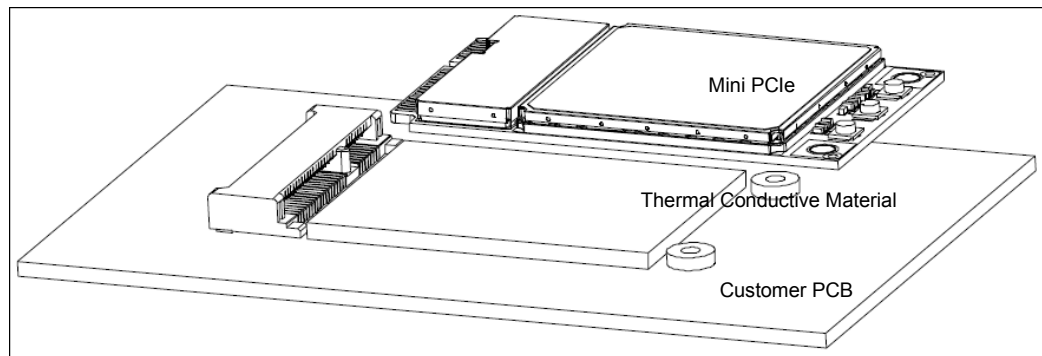

- On the customer PCB, reserve two metal screw holes, which are connected to the PCB ground plane. When installing the Mini PCIe, use two metal screws to fasten the Mini PCIe to the customer PCB. See the following figure.

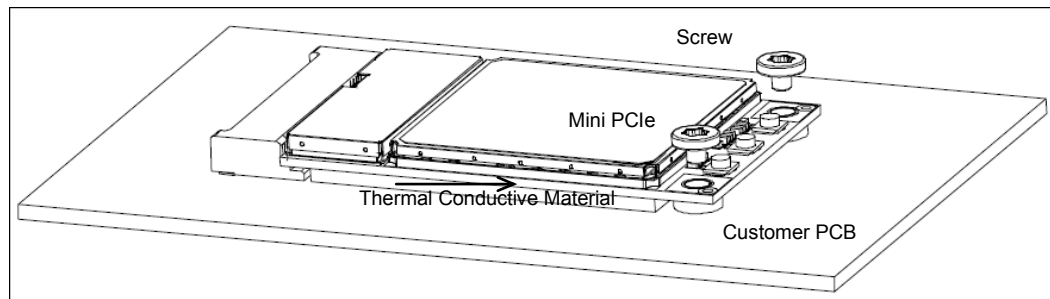

- Ensure that the air flow around the Mini PCIe is sufficient.
- Try not to place any component in the Mini PCIe's projection region on the customer PCB. Do not place components with 1.5 W or higher power consumption or heat sensitive components (such as crystals) near the Mini PCIe.
- Use a large customer PCB. The recommended size (W x D) is 70 mm x 70 mm (2.76 in. x 2.76 in.).
- If the thermal conductive material is attached between the Mini PCIe and the customer PCB, then the heat dissipation performance will be better for multilayer PCB.
- Apply copper to the region for attaching the thermal conductive material to the customer PCB. Try to use the continuous ground plane design on the customer PCB, and each ground plane must be connected through holes. Therefore, reserve holes as many as possible.



NOTE

If you do not take the preceding heat dissipation measures, the overheat protection mechanism is triggered due to overheated Mini PCIe and the network connection is terminated when the Mini PCIe keeps working in enclosed space with a 75°C temperature and a current of more than 800 mA for a period of time. You can resume the network connection only after the temperature drops.

7 Certifications

7.1 About This Chapter

This chapter gives a general description of certifications of ME209u-526 Mini PCIe module.

7.2 Certifications



NOTE

Table 7-1 shows certifications the ME209u-526 Mini PCIe module has been implemented. For more demands, please contact us for more details about this information.

Table 7-1 ME209u-526 Mini PCIe module product certifications

Certification	Model
	ME209u-526D
FCC	√

8 Safety Information

Read the safety information carefully to ensure the correct and safe use of your wireless device. Applicable safety information must be observed.

8.1 Interference

Power off your wireless device if using the device is prohibited. Do not use the wireless device when it causes danger or interference with electric devices.

8.2 Medical Device

- Power off your wireless device and follow the rules and regulations set forth by the hospitals and health care facilities.
- Some wireless devices may affect the performance of the hearing aids. For any such problems, consult your service provider.
- Pacemaker manufacturers recommend that a minimum distance of 15 cm be maintained between the wireless device and a pacemaker to prevent potential interference with the pacemaker. If you are using an electronic medical device, consult the doctor or device manufacturer to confirm whether the radio wave affects the operation of this device.

8.3 Area with Inflammables and Explosives

To prevent explosions and fires in areas that are stored with inflammable and explosive devices, power off your wireless device and observe the rules. Areas stored with inflammables and explosives include but are not limited to the following:

- Gas station
- Fuel depot (such as the bunk below the deck of a ship)
- Container/Vehicle for storing or transporting fuels or chemical products
- Area where the air contains chemical substances and particles (such as granule, dust, or metal powder)
- Area indicated with the "Explosives" sign

- Area indicated with the "Power off bi-direction wireless equipment" sign
- Area where you are generally suggested to stop the engine of a vehicle

8.4 Traffic Security

- Observe local laws and regulations while using the wireless device. To prevent accidents, do not use your wireless device while driving.
- RF signals may affect electronic systems of motor vehicles. For more information, consult the vehicle manufacturer.
- In a motor vehicle, do not place the wireless device over the air bag or in the air bag deployment area. Otherwise, the wireless device may hurt you owing to the strong force when the air bag inflates.

8.5 Airline Security

Observe the rules and regulations of airline companies. When boarding or approaching a plane, power off your wireless device. Otherwise, the radio signal of the wireless device may interfere with the plane control signals.

8.6 Safety of Children

Do not allow children to use the wireless device without guidance. Small and sharp components of the wireless device may cause danger to children or cause suffocation if children swallow the components.

8.7 Environment Protection

Observe the local regulations regarding the disposal of your packaging materials, used wireless device and accessories, and promote their recycling.

8.8 WEEE Approval

The wireless device is in compliance with the essential requirements and other relevant provisions of the Waste Electrical and Electronic Equipment Directive 2012/19/EU (WEEE Directive).

8.9 RoHS Approval

The wireless device is in compliance with the restriction of the use of certain hazardous substances in electrical and electronic equipment Directive 2011/65/EU (RoHS Directive).

8.10 Laws and Regulations Observance

Observe laws and regulations when using your wireless device. Respect the privacy and legal rights of the others.

8.11 Care and Maintenance

It is normal that your wireless device gets hot when you use or charge it. Before you clean or maintain the wireless device, stop all applications and power off the wireless device.

- Use your wireless device and accessories with care and in clean environment. Keep the wireless device from a fire or a lit cigarette.
- Protect your wireless device and accessories from water and vapour and keep them dry.
- Do not drop, throw or bend your wireless device.
- Clean your wireless device with a piece of damp and soft antistatic cloth. Do not use any chemical agents (such as alcohol and benzene), chemical detergent, or powder to clean it.
- Do not leave your wireless device and accessories in a place with a considerably low or high temperature.
- Use only accessories of the wireless device approved by the manufacture. Contact the authorized service center for any abnormality of the wireless device or accessories.
- Do not dismantle the wireless device or accessories. Otherwise, the wireless device and accessories are not covered by the warranty.
- The device should be installed and operated with a minimum distance of 20 cm between the radiator and your body.

8.12 Emergency Call

This wireless device functions through receiving and transmitting radio signals. Therefore, the connection cannot be guaranteed in all conditions. In an emergency, you should not rely solely on the wireless device for essential communications.

8.13 Regulatory Information

The following approvals and notices apply in specific regions as noted.

8.13.1 FCC Statement

Federal Communications Commission Notice (United States): Before a wireless device model is available for sale to the public, it must be tested and certified to the FCC that it does not exceed the limit established by the government-adopted requirement for safe exposure.



This device complies with Part 15 of the FCC Rules. Operation is subject to the following two conditions: (1) this device may not cause harmful interference, and (2) this device must accept any interference received, including interference that may cause undesired operation.

Warning: Changes or modifications made to this equipment not expressly approved by HUAWEI may void the FCC authorization to operate this equipment.

9 Appendix A Circuit of Typical Interface

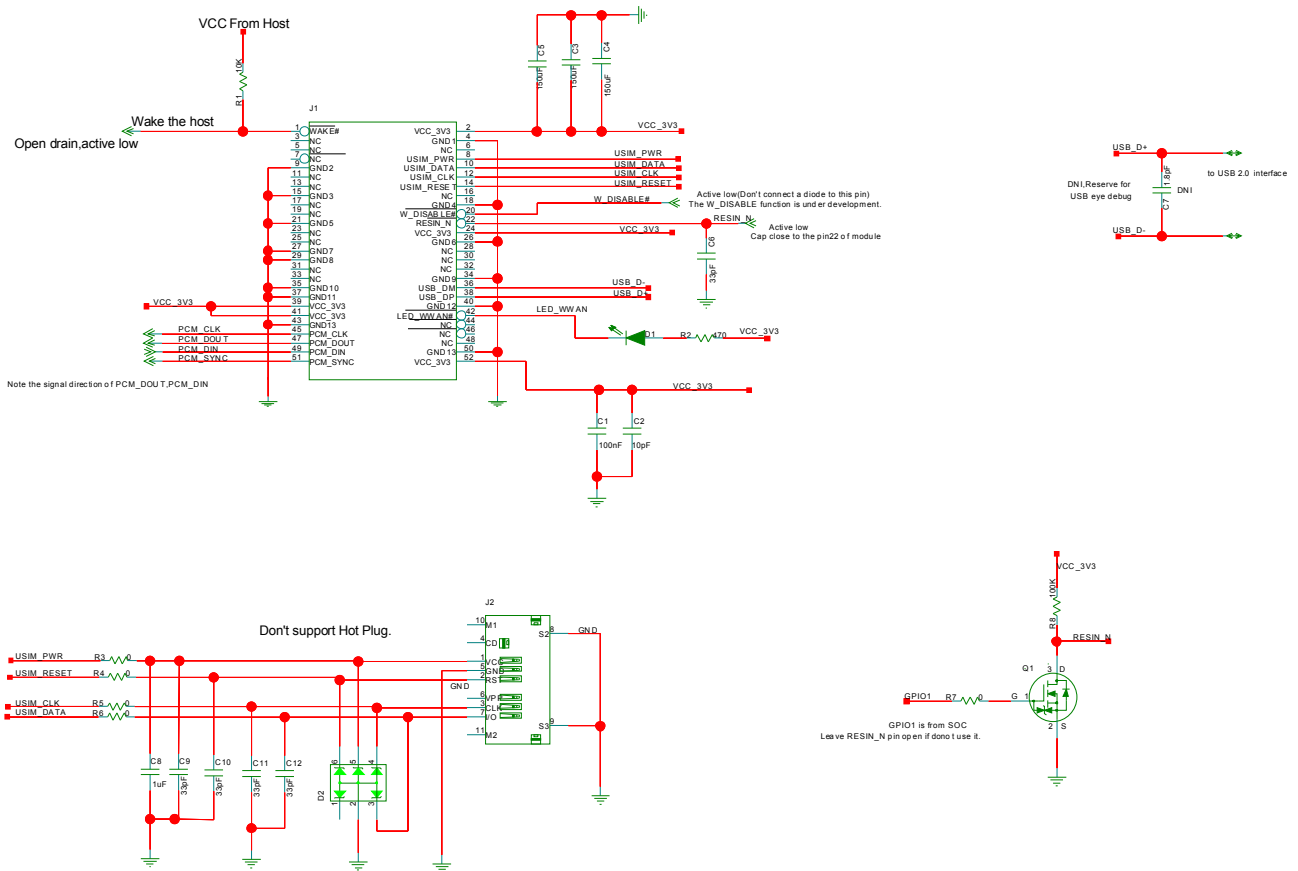

10 Appendix B Acronyms and Abbreviations

Acronym or Abbreviation	Expansion
3GPP	Third Generation Partnership Project
AUX	Auxiliary
DC	Direct Current
DCE	Data Communication Equipment
DL	Down Link
DTE	Data Terminal Equipment
EMC	Electromagnetic Compatibility
EPA	Electrostatic Discharge Protected Area
ESD	Electrostatic Discharge
EU	European Union
FCC	Federal Communications Commission
GPIO	General-purpose I/O
ISO	International Standards Organization
JTAG	Joint Test Action Group
LDO	Low-Dropout
LED	Light-Emitting Diode
LGA	Land Grid Array
MCP	Multi-chip Package
NC	Not Connected
PCB	Printed Circuit Board

Acronym or Abbreviation	Expansion
RF	Radio Frequency
RoHS	Restriction of the Use of Certain Hazardous Substances
SIMO	Single-input multiple-output
TIS	Total Isotropic Sensitivity
UART	Universal Asynchronous Receiver-Transmitter
UL	Up Link
USB	Universal Serial Bus
USIM	Universal Subscriber Identity Module
VSWR	Voltage Standing Wave Ratio
WEEE	Waste Electrical and Electronic Equipment
WWAN	Wireless Wide Area Network