

### HIGH PERFORMANCE GNSS SUPPORT FOR AIRBORNE MAPPING AND SURVEYING

#### KEY FEATURES

Full support for L1/L2 GPS + GLONASS and L-Band signals

Low-profile Fuselage Mounting

Sub-centimeter phase center repeatability

Fully certified for airborne installations

The Trimble AV37 GNSS Aviation Antenna has been designed to support centimeter level accuracy for airborne applications and track SBAS signals all in one compact design. It is fully certified by the FAA for aircraft installations.

#### ROBUST, CERTIFIED GNSS AVIATION ANTENNA

Mapping and surveying from the air using GNSS requires survey grade antenna technology in a compact and reliable form factor. The Trimble AV37GNSS Aviation antenna achieves this without compromising performance.



Trimble AV37 Antenna



# TRIMBLE AV37 GNSS AVIATION ANTENNA

## PERFORMANCE

- L1/L2 GNSS + L-Band Frequency Tracking:
  - GPS: L1, L2
  - GLONASS: L1, L2
  - Galileo: E1, E2
  - SBAS: WAAS, EGNOS, QZSS, Gagan, MSAS, and OmniStar
- Quality signal tracking
- TNC female signal connector
- Small cross-sectional area to reduce wind loading
- Low voltage, low power consumption
- Integral low noise amplifier
- Powered by GNSS receiver via coaxial cable
- High gain for reliable tracking in difficult environments
- FAA airworthiness certificate supplied with each antenna

## HARDWARE

- Dimensions..... 11.9 cm length, 7.6 cm width,  
2.3 cm height  
(4.7" length, 3.0" width, 0.92" height)
- Weight.....0.283 kg (0.62lb)
- Operating Temperature.....-55 °C to +85 °C (-67 °F to +185 °F)
- Altitude.....≤16,764 m (55,000 ft)
- Finish.....Polyurethane enamel, fluid resistant
- Compliance ..... ROHS
- Designed to..... DO-160E, ARINC 743 Footprint,  
RTCA DO-210D

## ELECTRICAL

- Frequencies.....1570 +/- 45 MHz  
1238 +/- 21.5 MHz
- Signal gain.....43 dB
- Voltage.....5 V DC to 15 V DC
- Polarization.....Right Hand Circular
- Axial Ratio.....3 dB Max @ boresight
- Amplifier.....Noise Figure : 2.5 dBMax  
Impedance : 50 Ohms  
VSWR : ≤ 1.5:

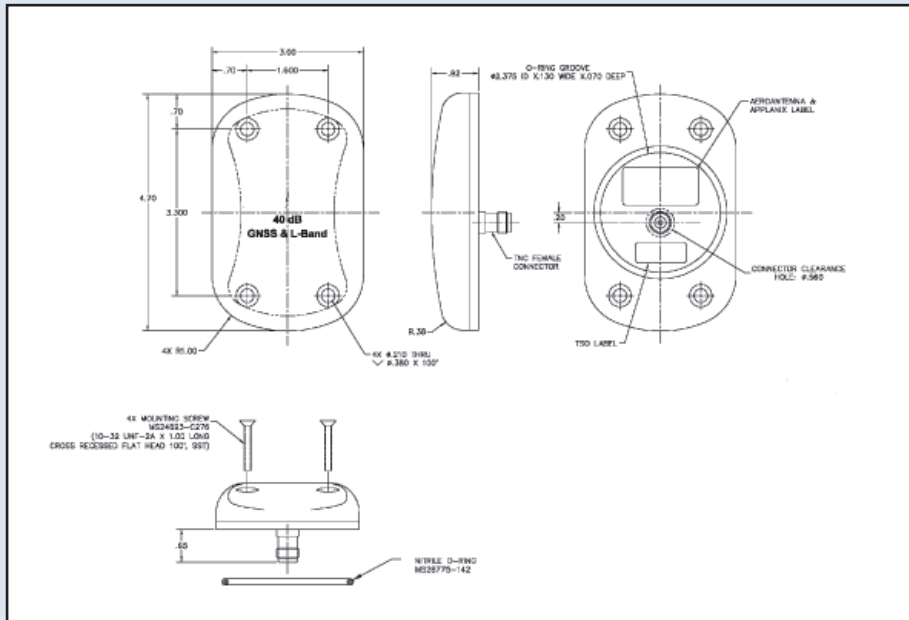

© 2012, Trimble Navigation Limited. All rights reserved. Trimble and the Globe & Triangle logo are trademarks of Trimble Navigation Limited, registered in the United States and in other countries. All other trademarks are the property of their respective owners. (09/12)



ר'ח' אודם 14, ת.ד. 7042 פ"ת ■ טל: 03-9243352 ■ פקס: 03-9243358

www.hypertech.co.il ■ sales@hypertech.co.il

