

CXTA

SOLID STATE, ANALOG SERIES

- Small, Low-Cost, Rugged
- Rapid Response
- $\pm 75^\circ$ Range
- Fully Conditioned Analog Outputs

Applications

- Scissor Lifts
- Static Platforms
- Survey Leveling Equipment
- Laser Leveling

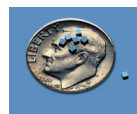
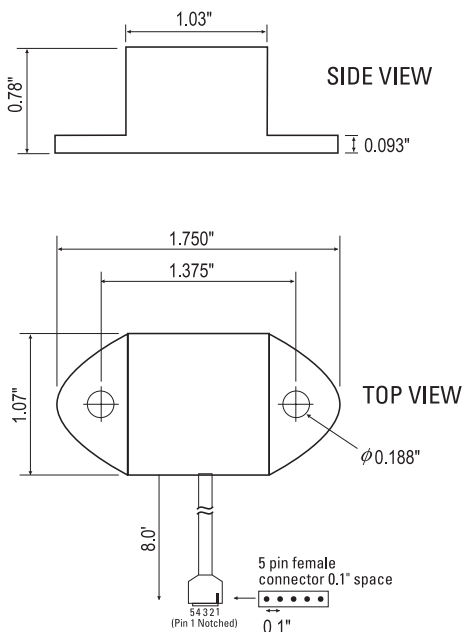

Micromachined
Tilt Sensor Element



CXTA01, CXTA02

The CXTA single- and dual-axis analog tilt sensors offer resolution, accuracy, and fast response in an inexpensive, easy-to-use package. The CXTA series design centers on a highly stable silicon micro-machined capacitive inclination sensor element. The CXTA series is fully signal conditioned with high level analog output(s), and optional analog temperature signal.

Micro-machined devices, perfected in automotive safety applications, offer several distinct advantages over fluid, electrolytic, and pendulum-based sensors. Like other solid-state devices, they are more reliable than their mechanical counterparts. In a package smaller than many pendulum or fluid raw sensing elements, completely integrated electronics eliminate the need for external components.

Unlike other micro-machined devices, the CXTA Series maintains its accuracy and stability over temperature: $< 2^\circ$ of arc over the range 0° to 70° C. The output can be user corrected for temperature with the T option, yielding accuracy to within $\pm 0.5^\circ$ over the angular range.

A typical configuration using CXTA sensors is shown below. Each module is factory calibrated, tested and includes a calibration sheet. The module can be securely attached using screws or adhesive. The CXTA is available in a standard nylon or high temperature aluminum package.

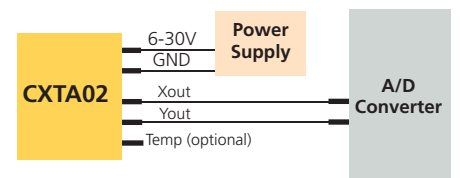

Typical CXTA02 Configuration



רח' אודם 14, ת.ד. 7042 פ"ת | טל: 03-9243352 | פקס: 03-9243385
sales@hypertech.co.il | www.hypertech.co.il



Specifications	CXTA01	CXTA02	Remarks
Performance			
Linear Angular Range (°)	± 20	± 20	
Full Angular Range (°)	± 75	± 75	
Angular Resolution (° rms)	0.05	0.05	
Sensitivity - small angles (mV/°)	35 ± 2	35 ± 2	Actual value provided with Sensor
Sensitivity Drift (%/°C)	0.01	0.01	
Zero Angle Voltage (Volts)	2.5 ± 0.15	2.5 ± 0.15	Actual value provided with Sensor
Zero Angle Drift (mV/°C)	1.0	1.0	Typical
Zero Angle Drift (°/°C)	0.03	0.03	Typical
Non-Linearity (°)	< 0.4	< 0.4	Over ± 20° not including Arcsine Error
Bandwidth (Hz)	50	50	
Settling Time (sec)	0.2	0.2	
Alignment (°)	± 1	± 1	Typical
Cross-axis Sensitivity (%)	< 5	< 5	Inclusive of alignment error
Environment			
Storage Temperature (°C)	-55 to +85	-55 to +85	Nylon Package
Operating Temperature (°C)	-40 to +85	-40 to +85	Nylon Package
Storage Temperature (°C)	-55 to +105	-55 to +105	-AL High Temperature Package
Operating Temperature (°C)	-40 to +105	-40 to +105	-AL High Temperature Package
Non-Operating Vibration (g rms)	10	10	20-2 kHz random
Shock (g)	2000	2000	1 ms, half sine
Electrical			
Supply Voltage (VDC)	6 - 30	6 - 30	Unregulated
Current (mA)	4	8	
Physical			
Size (Nylon Package)	.78 x 1.75 x 1.07" (1.98 x 4.45 x 2.72 cm)		
(Aluminum Package)	.95 x 2.00 x 1.20" (2.41 x 5.08 x 3.05 cm)		
Weight (Nylon Package)	1.38 oz (43 gm)		
(Aluminum Package)	2.09 oz (65 gm)		

Specifications subject to change without notice

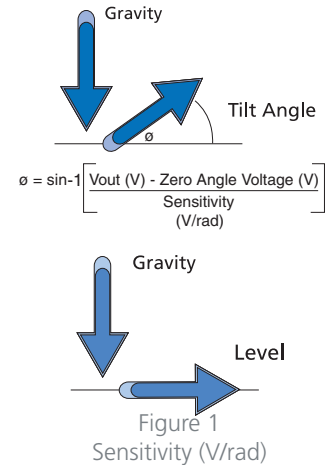

Principle of Operation

The CXTA Series Tilt Sensors use a micro-machined acceleration sensing element with a DC response to measure inclination relative to gravity. The response of the tilt sensor depends on the magnitude of gravity parallel to the sensor element. The output of the tilt sensor will be an offset voltage plus the voltage response proportional to the amount of gravity measured by the sensor.

Using the CXTA Sensor

The voltage response of the CXTA is proportional to the sine of the tilt angle.

Accurately measuring tilt angle involves solving the equation shown in Figure 1. To solve this equation the Zero Angle Voltage and Sensitivity must be determined prior to use, and the sensitivity must be converted to V/rad. MEMSIC provides this information on a calibration sheet with its CXTA products.

For angles less than 20°, the sine function can be approximated by a linear relationship between the Vout and the tilt angle in degrees. Thus the simplified equation for small angle in degrees is:

When the tilt angle is less than 20°, the error from linear approximation will be less than 2%. This is convenient when you don't have or want the computing power to calculate an inverse sine function.

$$\theta = \left[\frac{V_{out} - \text{Zero Angle Voltage}}{\text{Sensitivity}} \right]$$

Pin	Color	Function
1	Red	Power
2	Black	Ground
3	White	Roll
4	Yellow	Pitch
5	Green	Temp

Pin Diagram

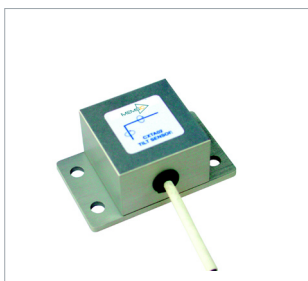

Optional Aluminum Package

Ordering Information

Model	Axes	Linear Range	Full Range	Resolution
CXTA01	X	± 20°	± 75°	0.05°
CXTA02	X,Y	± 20°	± 75°	0.05°
OPTIONS				
-T	Temperature Sensor Internal			
-AL	High Temperature Aluminum Package			